

UPWARE[®] VOLT



PART NO. UP12-5200

ABSORBED GLASS MAT VRLA INDUSTRIAL BATTERY BLOCK

Upware Volt™ UP Series VRLA Industrial Batteries provide superior high integrity and reliability for critical backup power applications. The maintenance-free valve regulated lead acid (VRLA) construction make Upware Volt™ UP Series batteries the definitive choice for UPS, telecom and utility applications.

UP SERIES FEATURES AND BENEFITS

- Tank formed lead-tin-calcium plates deliver consistent dependable performance and promote long life.
- Threaded copper insert terminals and epoxy post seal promote trouble-free service and eliminate acid egress.
- 99% gas recombination for extended life in float applications.
- Flame retardant ABS case and cover with UL94 V0 rating.
- UL 924 recognized flame arresting low pressure safety vents.
- 98% Recyclable.
- Classified as a Non-Spillable battery and is not restricted for transportation by air (IATA/ICAO prov. 67), Surface (DOT-CFR-HMR49), Water (Per IMDG Amendment 27).
- Ten year design life in float service.

PART NO. UP12-5200

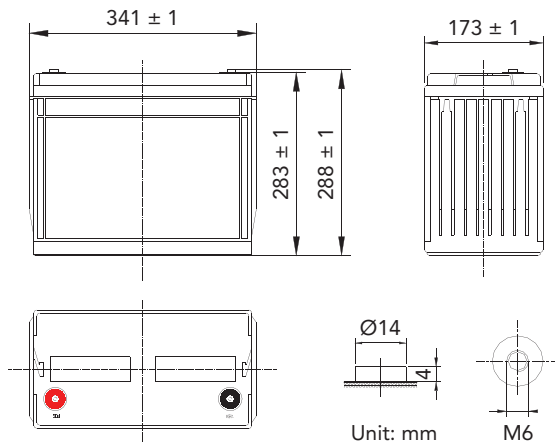

UP12-5200 SPECIFICATIONS

Length	341 mm	13.43 in
Width	173 mm	6.81 in
Height	283 mm	11.14 in
Total Height	288 mm	11.33 in
Weight	45.7 kg	100.75 lb
Volts	12v	
Terminal Torque	75 in-lbs (Annual retorque @ 75%)	
Terminal Type	M6 Threaded Insert	
Short Circuit	2500 Amps	
RINT	4.0 Milliohms	
Electrolyte	1.300 S.G.	
Self Discharge	3% per month @ 77°F/25°C	
20 hr Capacity	145Ah (77°F/25°C)	
10 hr Capacity	138Ah (77°F/25°C)	
8 hr Capacity	135Ah (77°F/25°C)	
5 hr Capacity	122Ah (77°F/25°C)	



Complies with DOT provisions listed in 49CFR173.159 (d). Special provision A67

UPWARE[®]

WWW.UPWAREINC.COM | 1 877 VOLT 911 | 1 877 865-8911

UPWARE[®] AND UPWARE VOLT™ ARE REGISTERED TRADEMARKS USED UNDER LICENSE WITH PERMISSION OF THEIR RIGHTFUL OWNER.

ABSORBED GLASS MAT VRLA INDUSTRIAL BATTERY BLOCK

OPERATING TEMPERATURES

Charging	-4°F/-20°C to 140°F/60°C
Discharge	14°F/-10°C to 140°F/60°C
Storage	-4°F/-20°C to 140°F/60°C

CHARGING

Float Charging	13.6 - 13.8 Volts @ 77°F/25°C
Cyclic Charging	14.5 - 14.9 Volts @ 77°F/25°C
AC Ripple	.5% RMS or 1.5% of float Voltage

UP12-5200 DISCHARGE CAPACITIES IN AMPERES TO VARIOUS END VOLTAGES AT 77°F 25°C

END VOLTAGE	30mins.	60mins.	2hrs.	3hrs.	4hrs.	5hrs.	6hrs.	8hrs.
1.60	188.0	103.0	58.8	44.0	34.5	28.8	24.0	18.5
1.75	182.0	102.0	57.5	43.1	33.7	28.2	23.5	18.3
1.80	175.0	100.0	56.0	42.0	32.8	27.5	23.0	18.0
1.85	168.0	98.0	54.5	40.8	31.9	26.8	22.5	17.7
1.90	160.0	95.5	52.8	39.5	30.8	26.0	21.8	17.3

UP12-5200 DISCHARGE RATINGS IN WATTS TO VARIOUS END VOLTAGES AT 77°F 25°C

END VOLTAGE	5mins.	10mins.	15mins.	20mins.	30mins.	45mins.	50mins.	60mins.
1.60	789.0	610.0	550.0	430.0	344.0	256.0	235.0	203.0
1.65	772.0	590.0	530.0	417.0	334.0	248.5	228.5	197.5
1.67	765.0	580.0	520.0	410.0	330.0	245.0	225.0	195.0
1.70	739.0	570.0	505.0	402.0	324.0	240.5	220.5	192.0
1.75	696.0	545.0	480.0	387.0	314.0	232.5	215.0	187.0

BATTERY CAPACITY VS. TEMPERATURE

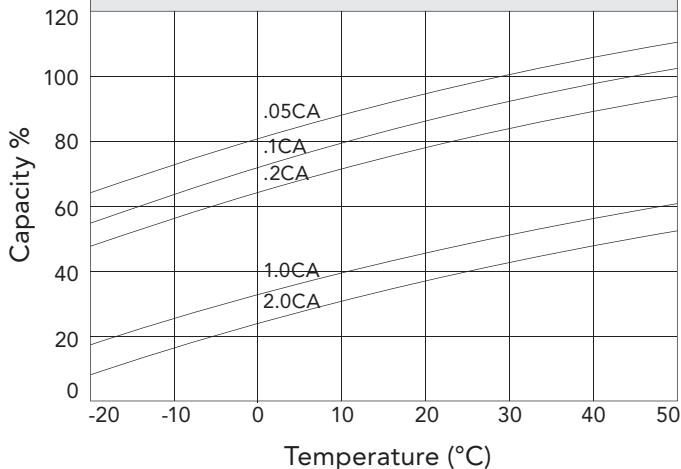

BATTERY FLOAT LIFE VS. TEMPERATURE

