

**MITSUBISHI  
ELECTRIC**

**UNINTERRUPTIBLE POWER SUPPLY SYSTEM**

**MODEL**

**2033A SERIES**

**OWNERS / TECHNICAL MANUAL**

# Preface

Revision 2.5 Sep. 10, 07  
ALN-H1271

---

**TABLE OF CONTENTS**

LIST OF TABLES .....	ii
LIST OF FIGURES .....	iii
HOW TO USE THIS MANUAL .....	iv
<b>1.0 INTRODUCTION</b> .....	1-1
1.1 SAFETY PRECAUTIONS .....	1-2
1.2 GENERAL .....	1-8
1.3 DEFINITIONS .....	1-9
1.4 OPERATION OVERVIEW .....	1-10
1.5 SPECIFICATIONS .....	1-16
<b>2.0 OPERATION CONTROLS AND INDICATORS</b> .....	2-1
2.1 LED DISPLAY .....	2-2
2.2 LIQUID CRYSTAL DISPLAY .....	2-3
2.3 EXTERNAL SIGNAL TERMINAL BLOCK .....	2-9
2.4 EXTERNAL COMMUNICATION CONNECTOR .....	2-12
<b>3.0 INSTALLATION AND OPERATION</b> .....	3-1
3.1 TRANSPORTATION AND INSTALLATION .....	3-1
3.2 INSTALLATION PROCEDURE .....	3-1
3.3 PROCEDURE FOR CABLE CONNECTIONS .....	3-2
3.4 OPERATING PROCEDURES .....	3-26
3.5 INTERNAL MAINTENANCE BYPASS SET-UP PROCEDURE .....	3-27
3.6 MAINTENANCE BYPASS SET-UP PROCEDURE FOR INPUT TRANS/MBP COMBINATION CABINET .....	3-28
<b>4.0 RESPONSE TO UPS FAILURE</b> .....	4-1
<b>5.0 PARTS REPLACEMENT</b> .....	5-1
<b>6.0 FAULT CODES</b> .....	6-1
<b>7.0 WARRANTY &amp; OUT OF WARRANTY SERVICE</b> .....	7-1

**LIST OF TABLES**

Table 1.1	UPS Installation Environment.....	1-6
Table 1.2	Rating of Bypass input circuit breaker .....	1-7
Table 1.3	Power Specifications.....	1-16
Table 1.4	UPS Module Information.....	1-16
Table 1.5	Input Transformer Cabinet Information (480V input).....	1-16
Table 1.6	Input/Output Transformer Cabinet Information .....	1-17
	(480V input, 480V output)	
Table 1.7	Input Transformer/MBP Cabinet Information (480V input) .....	1-17
Table 1.8	Detail of Specifications .....	1-18
Table 1.9	Rating of Circuit Breakers (MCCB) and Fuses.....	1-19
Table 3.1	How to Transport and Install the System .....	3-1
Table 3.2	List of UPS Weights (lb.).....	3-1
Table 3.3	Maximum Permitted Fault Current.....	3-2
Table 3.4a	Recommended Cable Size and.....	3-6
	Torque Requirements (for UPS)	
Table 3.4b	Recommended Cable Size and Torque Requirements.....	3-7
	(Input and output transformer field connections)	
Table 3.5a	Crimp Type Compression Lug (UPS) .....	3-8
Table 3.5b	Crimp Type Compression Lug (Transformer Field Terminations) ..	3-9
Table 3.6	Wiring configuration .....	3-10

**LIST OF FIGURES**

Figure 1.1	Single Line Diagram-Normal Operation.....	1-10
Figure 1.2	Single Line Diagram-Bypass Operation .....	1-11
Figure 1.3	Single Line Diagram-Battery Operation.....	1-12
Figure 1.4	Single Line Diagram - UPS on Maintenance Bypass Operation..	1-12
Figure 1.5	UPS Parts Location.....	1-14
Figure 2.1	Operation/Display Panel .....	2-1
Figure 2.2	Main Screen .....	2-3
Figure 2.3	Bypass Screen .....	2-3
Figure 2.4	Input Screen.....	2-4
Figure 2.5	Output Voltage Screen .....	2-4
Figure 2.6	Output Current Screen.....	2-4
Figure 2.7	Trend Graph Screen .....	2-5
Figure 2.8	Battery Screen .....	2-5
Figure 2.9	Remote / Local Selection Screen .....	2-5
Figure 2.10	Operation Menu Screen.....	2-6
Figure 2.11	Battery Operation Screen .....	2-7
Figure 2.12	Battery Low Voltage Screen .....	2-7
Figure 2.13	Discharge Termination Screen .....	2-7
Figure 2.14	Failure Indication Screen .....	2-8
Figure 2.15	External Signal Terminal Block.....	2-9
Figure 2.16	Control Wiring for External Contacts .....	2-10
Figure 2.17	Remote "Start" Contact Connections .....	2-11
Figure 2.18	External Communication Connector.....	2-12
Figure 3.1	UPS Terminal Designation .....	3-10
Figure 3.2	Input/Output Power Terminals.....	3-11 to 3-12
Figure 3.3	Wiring Configuration .....	3-13 to 3-25
Figure 3.4	Start-up Menu .....	3-26
Figure 3.5	Inverter Start / Stop.....	3-26

## HOW TO USE THIS MANUAL

This manual is designed for ease of use, giving the user easy and quick reference to information. This manual uses notice icons to draw attention to the user important information regarding the safe operation and installation of the UPS. The notice icons used in this manual are explained below, and should be taken into account and adhered to whenever they appear in the text of this manual.



**Warning:** A warning notice icon conveys information provided to protect the user and service personnel against hazards and/or possible equipment damage.



**Caution:** A caution notice icon conveys information provided to protect the user and service personnel against possible equipment damage.



**Note:** A Note notice icon indicates when the user should make a reference of information regarding the UPS operation, load status and display status. Such information is essential if Mitsubishi field service group assistance and correspondence is required.

**Safety Recommendations:** If any problems are encountered while following this manual, Mitsubishi field service group assistance and correspondence is recommended.

## 1.0 INTRODUCTION

The Mitsubishi Uninterruptible Power Supply (UPS) is designed to provide many years of reliable power supply and protection from power failure, brown-outs, line noise and voltage transients. To ensure optimum performance of the equipment, follow the manufacturer's instructions accordingly. This manual contains descriptions for the installation and operation procedures of the UPS. Please read this manual carefully and retain it for future reference.

**IMPORTANT SAFETY INSTRUCTIONS  
RETAIN THESE INSTRUCTIONS**



This manual contains important instructions for the 2033A Series Uninterruptible Power Supply Systems that should be adhered to during installation, operation and maintenance of the UPS and batteries.

**WARNING 1**



**Lethal voltages exist within the equipment during operation.  
Observe all warning and cautions in this manual.  
Failure to comply may result in serious injury or death.  
Obtain a qualified service for this equipment as per instructions.**

**WARNING 2**



**In no event will MITSUBISHI be responsible or liable for either indirect or consequential damage or injury that may come from the use of this equipment.**

**Any modifications without authorization by MITSUBISHI could result in personal injuries, death or destruction of the UPS.**

## 1.1 SAFETY PRECAUTIONS

The safety precautions are categorized as **DANGER** and **CAUTION** in this manual.

**DANGER**: A dangerous situation may occur if improperly handled, leading to severe or fatal injuries.

**CAUTION**: A dangerous situation may occur if improperly handled, leading to minor serious injuries.

Note that some items described as **CAUTION** may lead to severe results depending on the situation. Nonetheless, important information outlined in this section must be observed at all times.

### **DANGER**

- Do not dispose of the batteries in a fire as they may explode.
- Do not open or break the batteries. Released electrolyte is toxic and harmful to the eyes and skin.
- A battery can present a risk of electrical shock and high short circuit current. Observe the following minimum Safety Precautions when working on the batteries.
  - 1) Verify that the UPS is off and that the input power plug or wires are disconnected.
  - 2) Remove watches, rings or other metal objects.
  - 3) Use tools with insulated handles to prevent inadvertent shorts.
  - 4) Wear rubber gloves and boots.
  - 5) Do not lay tools or metal parts on top of the batteries.
  - 6) Determine if the battery is inadvertently grounded. If so, remove source of ground. Contact with any part of a grounded battery can result in electrical shock. The likelihood of such shock will be reduced if grounds are removed during installation and maintenance.

## CAUTION

### PRECAUTIONS FOR INSTALLATION

- **Do not block the intake/exhaust ports.**
  - If the intake/exhaust ports are blocked, the internal temperature of the UPS will rise and could lead to fires from battery electrolyte leakage, fire ignition or part deterioration.
- **Follow the UPS instruction manual carefully when installing the unit.**
  - Improper installation could lead to injury such as the UPS falling over, etc.

### PRECAUTIONS FOR WIRING

- **The power supply for this unit must be three phase rated in accordance with the equipment data plate. It must be suitably grounded.**
  - Failure to ground the unit could lead to electrical shocks.

### PRECAUTIONS FOR USE

- **If a unit fault, abnormal odor or noise occurs, turn off the UPS input switch.**
  - Failure to do so could lead to fires.
- **Do not insert blunt objects or fingers, etc., in the fan.**
  - Failure to observe this could lead to injuries.
- **Do not insert blunt objects or fingers, etc., into the unit's input/output section.**
  - Failure to observe this could lead to electrical shocks.
- **Ventilate the UPS surroundings.**
  - Failure to do so could lead to container rupture or to explosions from the gas generated from the battery system.
- **Prohibit smoking and the use of fire around the unit.**
  - Failure to do so could lead to injuries, damage or fires from explosions.
- **Do not place containers that have water or any liquids on the UPS.**
  - If the container tips over and the water or liquids spills, this could lead to electrical shocks and to fires in the UPS.
- **Do not sit on, step on or lean on the UPS.**
  - Failure to observe this could lead to injuries if the UPS tips over.

## CAUTION

### PRECAUTIONS FOR MAINTENANCE AND INSPECTION

- **The inside of the UPS must be inspected or repaired only by qualified personnel.**
  - Failure to observe this could lead to electrical shocks, injuries, burns, smoke generation or fires.
- **Periodically replace the battery.**
  - Batteries that have exceeded the replacement life could lead to fires from electrolyte leakage or fire ignition.
- **Contact the dealer or service company for unit maintenance and repairs, and for the replacement of defective parts.**
  - Opening the cover could lead to electrical shocks or burns.

### PRECAUTIONS FOR BATTERY

- **If the battery ignites, do not use water to extinguish the fire. Instead, use a powder (ABC) fire extinguisher.**
  - Use of water could cause the fire to grow.
- **Toxic diluted sulfuric acid in the battery.**
  - If electrolyte leaks from the unit, avoid contact with the skin or clothes.  
If electrolyte makes contact with the skin or clothes, wash it off thoroughly with clean water.  
If electrolyte makes contact with the eyes, rinse immediately and thoroughly with clean water, and then see a doctor. The presence of sulfuric acid in the eyes could lead to blindness, and adherence to skin could lead to burns.

### OTHER PRECAUTIONS

- **Never use or store the unit in the following types of environment:**
  - a) A location having a low or high temperature, or high humidity deviated from the ambient environment conditions described in the brochure or instruction manual.
  - b) A location submerged in water or where the unit could become wet from dripping water.
  - c) At an altitude higher than 9000 feet (2700 meters).
  - d) In direct sunlight.
  - e) Where organic solvents (gasoline, paint thinner, etc.) are stored.
  - f) A location that is dusty.
  - g) A location containing combustible gas, corrosive gas, salt or oil mist.
  - h) A location subject to vibration or impacts.
  - i) A location near devices that generate sparks or near heating elements.

**APPLICATION**

**This UPS shall NOT be applied to support equipment (\*) that could affect the human lives.**

**Special considerations are required when applying this UPS to the equipment (\*\*) that affect human safety and/or maintain public services.**

**Be sure to contact/inform MITSUBISHI if it is such a case. The application without special consideration may cause serious accidents.**

- \*
  - Medical operation room equipment
  - Life support equipment (artificial dialysis, incubators, etc.)
  - Toxic gas or smoke eliminators
  - Equipment that must be provided under fire laws, construction standards or other ordinances
  - Equipment equivalent to the above
  
- \*\*
  - Equipment to supervise or control airways, railways, roads, sea-lanes or other transportation.
  - Equipment in nuclear power plants.
  - Equipment to control communications.
  - Equipment equivalent/similar to the above mentioned.

**WARNING 3**

**The UPS is to be installed in a controlled environment.**

**Improper storage and installation environment may deteriorate insulation, shorten component life and cause malfunctions.**

**Keep the installation environment per standard described as follows:**

**TABLE 1.1** UPS Installation Environment

No.	Item	Environment standard	
1	Installation location	Indoors	
2	Ambient temperature	Minimum temperature: 32°F(0°C), Maximum temperature: 104°F(40°C) The average temperature over any 24-hour period must be in the range 41° F (5°C) to 95°F(35°C).	
3	Relative humidity	The relative humidity must be held between 5 and 95%. There must be no condensation due to temperature changes.	
4	Altitude	This equipment must not be applied at altitude that exceeds 1000m(3300ft) above seal level.	
5	Dust	Dust in the room where the UPS is installed must not exceed normal atmospheric dust levels. In particular, that dust should not include iron particles, oils or fats, or organic materials such as silicone.	
6	Inflammable gas	There should be no inflammable/explosive gas.	
		Hydrogen sulfide (H <sub>2</sub> S)	No more than 0.0001 PPM
		Sulfurous acid gas (SO <sub>2</sub> )	No more than 0.05 PPM
		Chlorine gas (Cl <sub>2</sub> )	No more than 0.002 PPM
		Ammonia gas (NH <sub>3</sub> )	No more than 0.1 PPM
		Nitrous acid gas (NO <sub>2</sub> )	No more than 0.02 PPM
		Nitrous oxides (NO <sub>x</sub> )	No more than 0.02 PPM
		Ozone (O <sub>3</sub> )	No more than 0.002 PPM
	Hydrochloric acid mist (HCl)	No more than 0.1 mg/m <sup>3</sup>	

**WARNING 4**



This UPS does not include a Bypass Input circuit breaker (MCCB). The Bypass Input contactor (CB3) does not protect against load induced short circuits. The bypass input circuit breaker (MCCB) is field supplied and installed. When Bypass Input is fed by an input transformer the requirement for Bypass Input circuit breaker can be met with circuit breaker (MCCB) on the primary side of the transformer. Circuit breaker (MCCB) specifications are as follows:

**TABLE 1.2** Rating of Bypass input circuit breaker

Capacity (kVA)	Bypass Voltage (VAC)	Maximum Bypass Rating (AAC)	Recommended Breaker (A)
30	208	83	125
	480	36	50
	600	29	35
40	208	111	150
	480	48	70
	600	39	50
50	208	139	175
	480	60	80
	600	48	60
75	208	208	300
	480	90	125
	600	72	90

AC input and AC output over current protection and disconnect devices shall be field supplied and installed. DC output over current protection and disconnect device shall be field supplied and installed.

## **1.2 GENERAL**

The Mitsubishi 2033A Series UPS is designed to provide continuous and clean electrical power to a critical load. In the event of an input power failure, the UPS will supply power to the critical load for the specified battery time.

If the input power is not restored promptly, back up power from the UPS battery permits the orderly shutdown of equipment supported by the UPS. The UPS is simple to start up, operate and maintain.

The 2033A Series UPS is available in four (4) kVA sizes: 30, 40, 50 and 75kVA. Specifications for each kVA model appear in Section 1.5. The principles of operation described herein are applicable to all models.

This manual provides an overview of the 2033A Series components and their functions. The appearance and purpose of operator controls and indicators are described with procedures for operation, start-up, shutdown and basic maintenance included.

### 1.3 DEFINITIONS

**UNINTERRUPTIBLE POWER SUPPLY SYSTEM (UPS)** - All components within the UPS Module Cabinet includes the batteries which function as a system to provide continuous, conditioned AC power to a load. This is sometimes referred to as the "System".

**UPS MODULE CABINET** - The metal enclosure which contains the Converter / Charger, the Inverter, the Static Transfer Switch, the Internal Bypass line, the operator controls, and the internal control system required to provide specified AC power to a load.

**UPS MODULE** - The Converter / Charger and Inverter assemblies which, under the direction of the internal control system and operator controls, provide specified AC power to a load.

**CONVERTER / CHARGER** - The UPS components which contain the equipment and controls necessary to convert input AC power to regulated DC power required for battery charging and for supplying power to the Inverter.

**INVERTER** - The UPS components which contain the equipment and controls necessary to convert DC power from the Converter / Charger, or the battery, to AC power required by the critical load.

**STATIC TRANSFER SWITCH** - The device which connects the critical load to the bypass line when the UPS module cannot supply continuous power.

**BYPASS LINE** - The line which conducts electricity directly from the input power source to the critical load during Maintenance or whenever the UPS is not completely operational.

**INPUT POWER** - Power provided by the electrical utility company, or auxiliary generator, which is connected to the UPS for supplying the critical load.

**MAINTENANCE BYPASS SWITCH** – Internal wrap-around make-before-break rotary switch used to provide load and personnel safety when UPS is being maintained.

**1.4 OPERATION OVERVIEW**

The UPS provides two power paths between the utility source and the critical load as shown in Figures 1.1 and 1.2.

**FIGURE 1.1** Single Line Diagram - Normal Operation. Load powered through inverter.

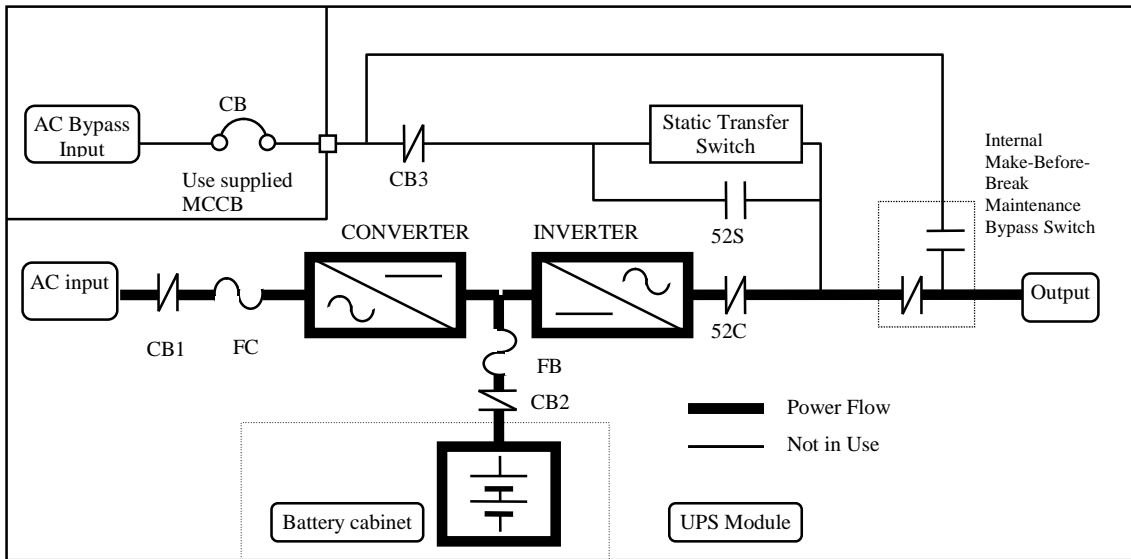

When the load is on the Inverter, the internal control system determines which of the two paths supplies power to the load. During normal operation, the path through the UPS module is used.

Input AC power flows through the UPS where it is converted to DC by the Converter/Charger. This DC power is utilized to charge the UPS battery and to provide power to the Inverter. The Inverter converts the DC power to clean AC power to supply the critical load.

The conversion - inversion process eliminates any voltage transients or fluctuations existing in the input power before it reaches the critical load.



**\* The Bypass Input circuit breaker (MCCB) for protection of the UPS and cables are field supplied and field installed.**

**FIGURE 1.2** Single Line Diagram - Internal Bypass. Load fed through static bypass line.

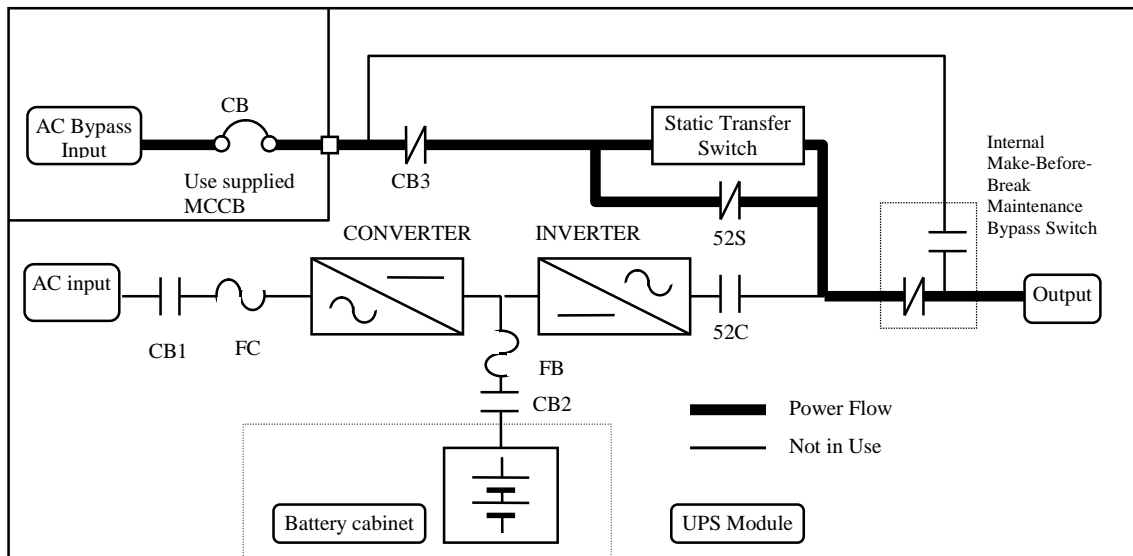

The Internal Static Bypass line is a Hard wired line through CB3, contactor 52S which supplies the critical load with unconditioned input power. The purpose of this line is to route power to the critical load while the UPS module is de-energized during Start-up before the system is fully operational.

If the input power is interrupted, the battery will immediately supply the DC power required by the Inverter to maintain continuous AC power to the load. A fully charged battery will provide power for the specified time at the rated load, or longer, at a reduced load.

When power is restored after a low battery shutdown, the Converter/Charger automatically restarts operation, recharges the batteries, and the Inverter is automatically restarted without operator intervention. The load is assumed by the inverter automatically without operator intervention.

In the event of a power failure, the converter will de-energize and the batteries will discharge into the inverter and maintain power to the critical until a) the battery capacity expires and the inverter turns off, or b) input power is restored after which the converter will power the critical load and simultaneously recharge the batteries. Figure 1.3 illustrates the flow diagram during battery operation.

**FIGURE 1.3** Single Line Diagram - Battery Operation

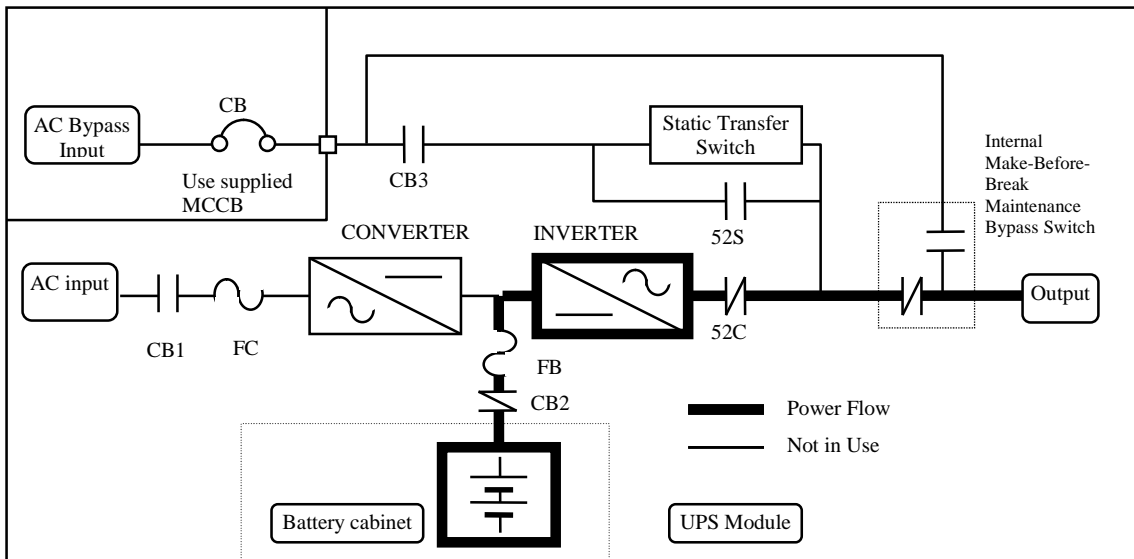

The UPS is equipped with an internal rotary type Maintenance Bypass Switch (MBS) that can be used to divert utility power to the load during maintenance sessions. Figure 1.4 illustrates the power path during when the MBS is in the BYPASS mode.

**FIGURE 1.4** Single Line Diagram - UPS on Maintenance Bypass Operation.

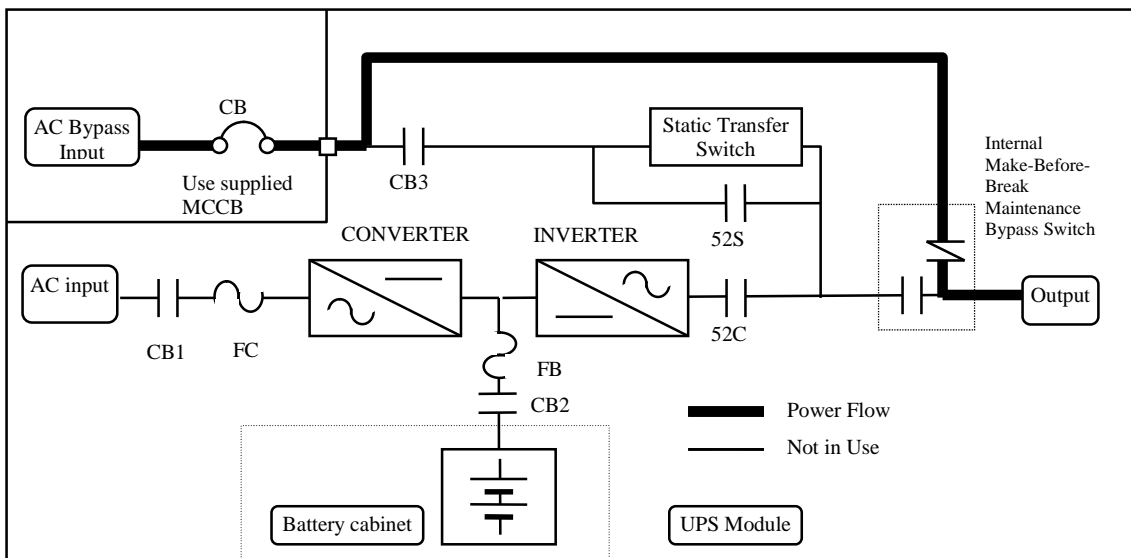

The rotary maintenance bypass switch is identified as 52CS in Figure 1.4. 52CS is a two position make-before-break transfer switch. The two positions are identified as NORMAL and BYPASS. In the NORMAL position the load is fed by the UPS - either through the inverter or through the static bypass line. In the BYPASS position the load is powered by an external source such as the utility or a generator. This transfer operation must be made while the UPS is in the static bypass mode.

The transfer procedure to place the UPS in the maintenance bypass mode, and vice versa, is outlined below:

#### **TRANSFER FROM NORMAL MODE TO MAINTENANCE BYPASS MODE**

1. With inverter running, confirm "Inverter Sync." displayed on UPS LCD (Liquid Crystal Display) is ON.
2. Press the inverter "STOP" key on UPS LCD.
3. Confirm UPS is on static bypass.
4. Rotate rotary switch from "NORMAL" position to "BYPASS" position.
5. Transfer is complete. UPS can now be powered down for maintenance. Load is fed by utility or generator source. CB3 can be opened with SW2 (CB3 close/open SWITCH).

#### **TRANSFER FROM MAINTENANCE BYPASS MODE TO NORMAL MODE**

1. Confirm CB3 inside the UPS cabinet is closed (ON) with inverter running.
2. With inverter running, confirm "Inverter Sync." displayed on UPS LCD is ON.
3. Press the inverter "STOP" key on UPS LCD.
4. Confirm UPS is on static bypass.
5. Rotate rotary switch from "BYPASS" position to "NORMAL" position.
6. Press the inverter "START" key on UPS LCD.
7. UPS will transfer to inverter automatically within a few seconds.
8. Load is now powered by the inverter.

**FIGURE 1.5 UPS Parts Location**

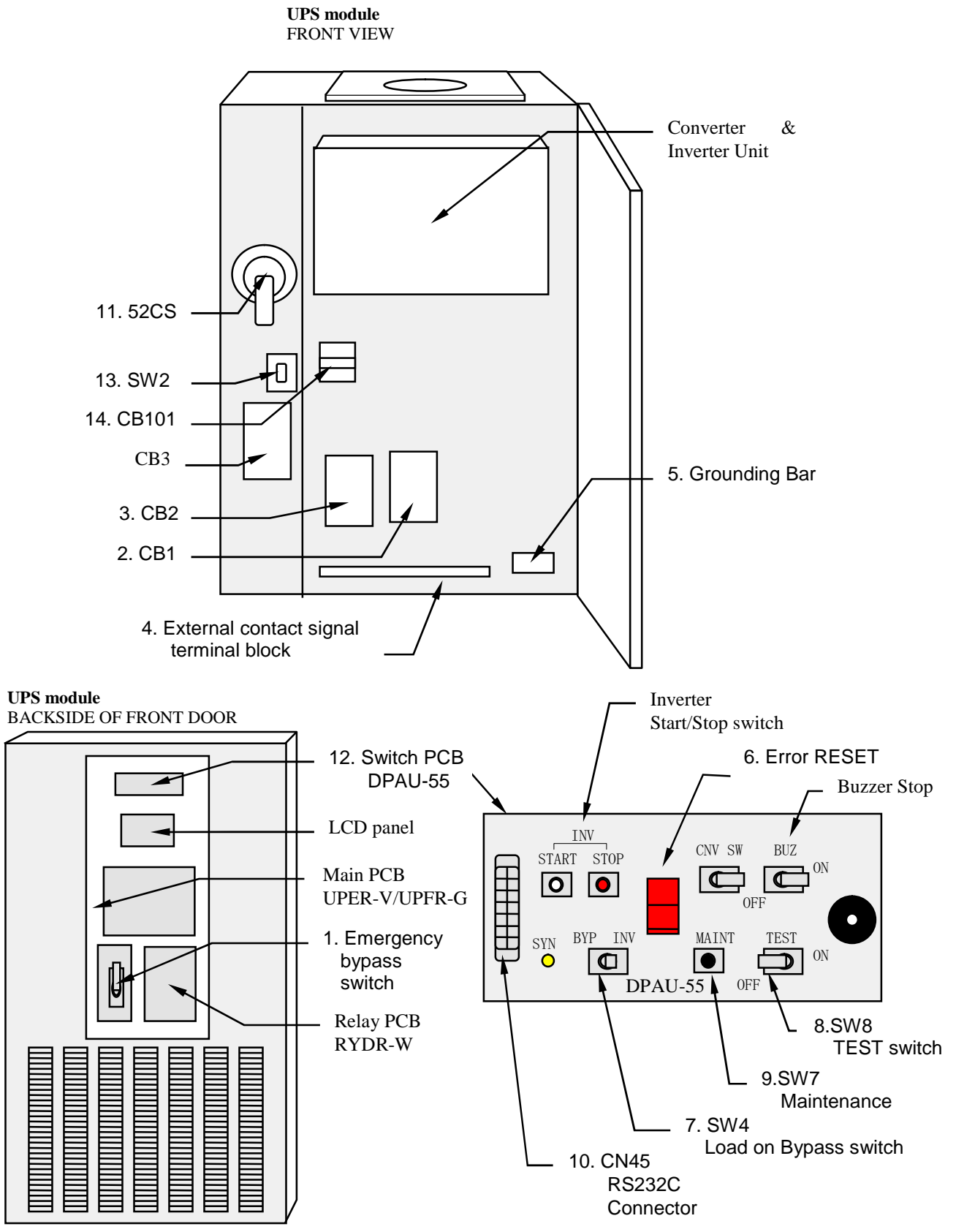

Description of Figure 1.5:

1. **Emergency bypass switch (SW1)** This switch activates the bypass power supply for emergency reasons if the UPS is turned off. Normal position is "TRANSFER is PERFORMED".
2. **AC Input circuit contactor (CB1)** Contactor for converter input power.
3. **Battery Disconnect circuit contactor (CB2)** Contactor for battery input.
4. **External contact signal terminal block** Terminal block to connect contact signal input/output lines to and from external dry contacts. Refer to FIGURE 2.8 for details.
5. **Grounding bar (E).**
6. **"Error reset" switch** This switch resets errors resulting from alarm conditions. (Do not operate this switch while inverter and converter are in operation).
7. **Bypass manual change-over switch (FOR SERVICE PERSONNEL ONLY)** This switch is used to transfer the UPS from inverter to static bypass for maintenance purposes. Do not operate it under normal operation. Transfers will be locked-out if the bypass voltage is more than  $\pm 10\%$  of nominal. 1) Uninterrupted switching is made at the time of synchronous operation. Switching is impossible at the time of asynchronous operation. 2) Return to "Normal" after use.
8. **"Test mode" switch** This switch should be operated Authorized Service Personnel only.
9. **Maintenance (Set) switch** This switch sets the UPS menu parameters.
10. **RS232C connector (CN45)**
11. **Maintenance Bypass Switch (52CS).**
12. **Switches on DPAU board : FOR SERVICE PERSONNEL ONLY (Figure 1.6):**
  - (6) Error RESET.
  - (7) SW4 (Load on Bypass Switch)
  - (8) SW8 (TEST Switch): Normal="Off" side.
  - (9) SW7 (Maintenance Set Switch).
  - (10) CN45 (RS232C communication connector)
13. **SW2** operates contactor CB3. For maintenance of UPS only. Normal position is "ON".
14. **Control Power circuit breaker (CB101)**

## 1.5 SPECIFICATIONS

The UPS name plate displays the rated kVA as well as nominal voltages and currents. The nameplate is located on the interior side of the UPS front door.

**TABLE 1.3** Power Specifications

<b>Rated output Power</b>	<b>Input voltage 3 ph / 3 wire</b>	<b>Output voltage 3 ph /3 or 4 wire</b>
30kVA / 24kW	208, 480, or 600	208, 480, or 600
40kVA / 32kW	208, 480, or 600	208, 480, or 600
50kVA / 40kW	208, 480, or 600	208, 480, or 600
75kVA / 60kW	208, 480, or 600	208, 480, or 600

**TABLE 1.4** UPS Module Information

<b>UPS (kVA)</b>	<b>CABLE ENTRY</b>	<b>WIDTH (in/mm)</b>	<b>DEPTH (in/mm)</b>	<b>HEIGHT (in/mm)</b>	<b>WEIGHT (lb.)</b>	<b>HEAT LOSS @ 208V (kBTU/h)</b>
30	BOTTOM	35.4 / 900	29.5 / 750	70.9 / 1800	1050	11.0
40/50	BOTTOM	43.3 / 1100	29.5 / 750	70.9 / 1800	1450 / 1470	13.9 / 16.6
75	BOTTOM	43.3 / 1100	29.5 / 750	70.9 / 1800	1700	23.5

**TABLE 1.5** Input Transformer Cabinet Information (480V input)

<b>UPS (kVA)</b>	<b>CABLE ENTRY</b>	<b>WIDTH (in/mm)</b>	<b>DEPTH (in/mm)</b>	<b>HEIGHT (in/mm)</b>	<b>WEIGHT (lb.)</b>	<b>HEAT LOSS @ 480V (kBTU/h)</b>
30	TOP	16.1 / 410	29.1 / 740	70.9 / 1800	535	3.6
40	TOP / BOTTOM	24.1 / 610	29.1 / 740	70.9 / 1800	650	4.8
50	TOP / BOTTOM	24.1 / 610	29.1 / 740	70.9 / 1800	710	6.0
75	TOP / BOTTOM	24.1 / 610	29.1 / 740	70.9 / 1800	930	9.0

**TABLE 1.6** Input/Output Transformer Cabinet Information (480V input, 480V output)

<b>UPS (kVA)</b>	<b>CABLE ENTRY</b>	<b>WIDTH (in/mm)</b>	<b>DEPTH (in/mm)</b>	<b>HEIGHT (in/mm)</b>	<b>WEIGHT (lb.)</b>	<b>HEAT LOSS @ 480V (kBTU/h)</b>
30	TOP / BOTTOM	24.1 / 610	29.1 / 740	70.9 / 1800	930	6.7
40	TOP / BOTTOM	24.1 / 610	29.1 / 740	70.9 / 1800	1255	9.0
50	TOP / BOTTOM	24.1 / 610	29.1 / 740	70.9 / 1800	1350	11.2
75	TOP / BOTTOM	24.1 / 610	29.1 / 740	70.9 / 1800	1750	16.8

**TABLE 1.7** Input Transformer/MBP Cabinet Information (480V input)

<b>UPS (kVA)</b>	<b>CABLE ENTRY</b>	<b>WIDTH (in/mm)</b>	<b>DEPTH (in/mm)</b>	<b>HEIGHT (in/mm)</b>	<b>WEIGHT (lb.)</b>	<b>HEAT LOSS @ 480V (kBTU/h)</b>
30	TOP / BOTTOM	30.3 / 700	29.1 / 740	70.9 / 1800	910	3.6
40	TOP / BOTTOM	30.3 / 700	29.1 / 740	70.9 / 1800	950	4.8
50	TOP / BOTTOM	30.3 / 700	29.1 / 740	70.9 / 1800	990	6.0
75	TOP / BOTTOM	24.1 / 610	29.1 / 740	70.9 / 1800	1310	9.0

**TABLE 1.8** Detail of Specifications

Rated Output kVA	30	40	50	75
Rated Output kW	24	32	40	60
<b>AC INPUT CHARACTERISTICS</b>				
Configuration	3 phase, 3 wire			
Voltage	208 V, 480 V, 600 V +10% ~ -15%			
Input Power Factor	0.98 typical			
Frequency	60 Hz $\pm$ 5%			
Reflected Current THD	3% max. at 100% load; 5% max. at 50% load			
<b>STATIC BYPASS INPUT</b>				
Configuration	3 phase, 3 or 4 wire			
Voltage	120/208 V, 277/480 V, 346/ 600 V $\pm$ 10%			
Frequency	60 Hz ( $\pm$ 3% Tracking window)			
<b>BATTERY</b>				
Type	VRLA, Flooded Lead Acid, Nickel Cadmium			
Ride Through	Application Specific			
Nominal Voltage	360 VDC			
Minimum Voltage	300 VDC			
Number of Cells	176 ~ 185			
<b>AC OUTPUT</b>				
Configuration	3 phase, 3 or 4 wire			
Voltage	120/208 V, 277/480 V, 346/ 600 V			
Voltage Stability	$\pm$ 1%			
Frequency	60 Hz			
Frequency Stability	$\pm$ 0.01% in free running mode			
Power Factor	0.8 nominal			
Power Factor range	0.8 ~ 1.0 lagging (within output kW rating)			
Voltage THD	2% maximum THD at 100% Linear Load 4% maximum THD at 100% non-linear load			
Transient Response	$\pm$ 3% maximum at 100% load step $\pm$ 1% maximum at loss or return of AC power $\pm$ 3% maximum at load transfer to/from static bypass			
Transient Recovery	Less than 1 line cycle			
Voltage Unbalance	2% maximum at 100% unbalanced load			
Phase Displacement	1% maximum at 100% unbalanced load			
Inverter Overload	125% for 10 minutes; 150% for 10 seconds			
System Overload	1000% for 1 cycle (with bypass available)			
Bypass Overload	125% for 10 minutes			
Withstand Rating	65kA* *:with optional fuses (only 208V model)			
<b>ENVIRONMENTAL</b>				
Cooling	Forced Air			
Operating Temperature	32° F ~ 104° F (0° C ~ 40° C). Recommended 68° F ~ 86° F (20° C ~ 30° C)			
Relative Humidity	5% ~ 95% Non Condensing			
Altitude	3300 Feet (1000 meters); 9000 feet @ 0.99 derating			
Location	Indoor (free from corrosive gases and dust)			
Paint Color	Munsell 5Y7/1 (Beige)			





**TABLE 1.9** Rating of Circuit Breakers (MCCB) and Fuses

Component(s)	Description	Component Rating @ 208V, 480V, 600V 3 phase, 60 Hz			
		UPS Rating (kVA)	30	40	50
CB1	AC Input Contactor	65A	150A	150A	220A
CB2	DC Input Contactor	65A	150A	150A	220A
CB3	Static Bypass Input Contactor	65A	150A	150A	220A
CB101	Control Power Circuit Breaker	15 A			
FCU, FCV, FCW	Converter Input Fuse	140A/690Vac	180A / 660Vac		280A/660Vac
FBP	Battery Input Fuse	140A/690Vac	180A / 660Vac		280A/660Vac
(OPTION) FSU, FSV, FSW	Bypass Input Fuse (only 208V model)	125A/660Vac	250A/660Vac		350A/660Vac
FUD1, FUD2	Control Power Supply Input Fuse	10A / 500Vdc			
FTR1, FTR2	Display Circuit Fuse	10A / 600Vac			
FUS1, FUS2, FUS3	Bypass Voltage Sensor Fuse	10A / 600Vac			
FZS1, FZS2, FZS3	Bypass Input Zener Fuse	30A / 600Vac			
FBS1, FBS2	CB3 Coil Input Fuse	10A / 600Vac			

\* Rating would be changed.

## 2.0 OPERATOR CONTROLS AND INDICATORS

The 2033A Series operator controls and indicators are located as follows:

- Circuit breakers and contactors : Inside the module
- UPS status indicators : Outside of door

**FIGURE 2.1** Operation/Display Panel (Front panel)

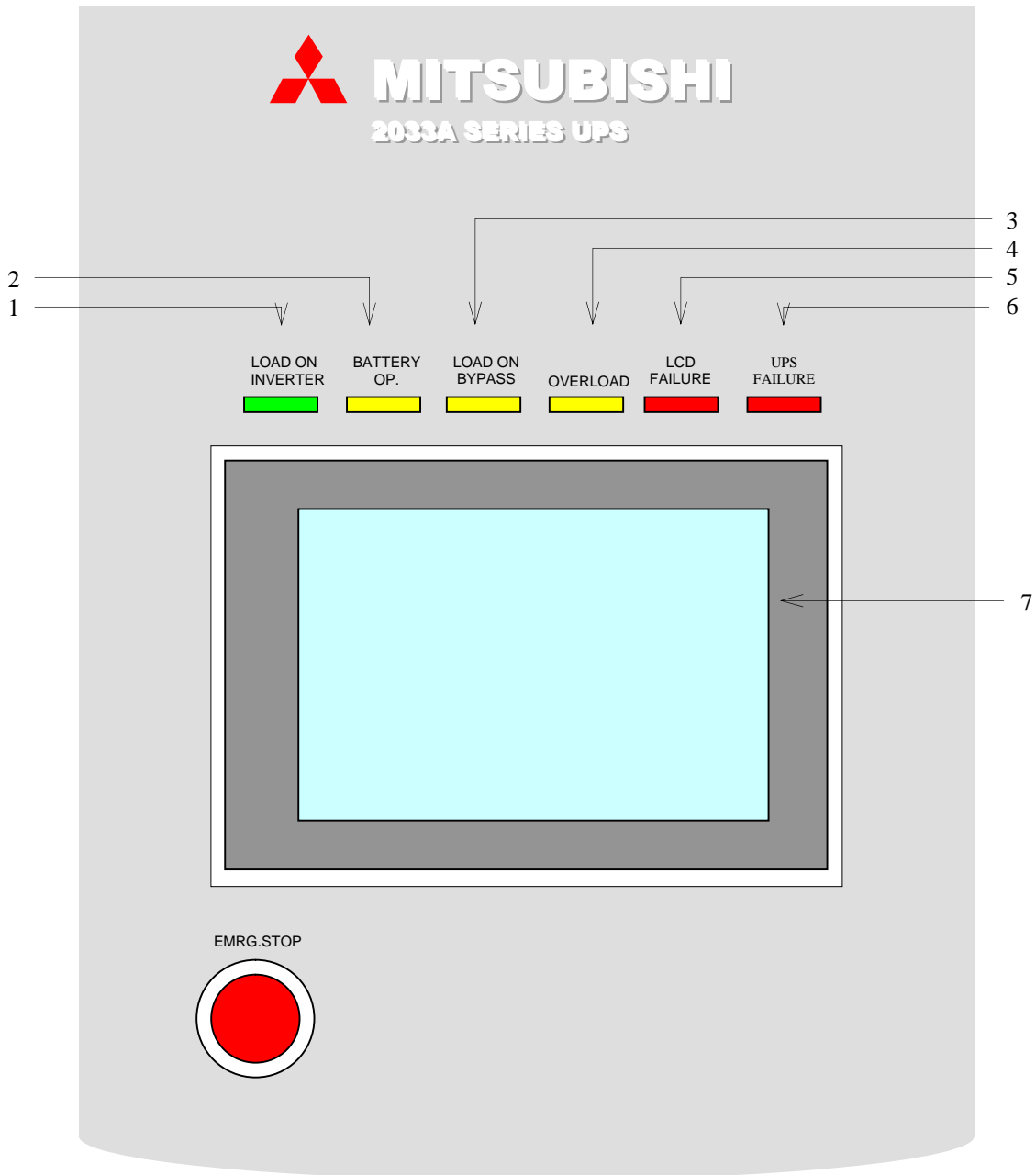

## 2.1 LED Display

1) **Load on inverter (green)**

Turned on when power is supplied from inverter to the critical load.  
(Indicates the state of transfer switch "52C" of inverter.)

2) **Battery operation (yellow)**

Turned on when the battery is operating following an AC power failure..

3) **Load on bypass (yellow)**

Turned on when power is supplied through bypass to load devices.  
(Indicates the state of transfer switch "52S" of bypass.)

4) **Overload (yellow)**

Turned on when an overload has occurred to the system.

5) **LCD failure [ LCD FAIL ](red)**

Turned on when an error occurs on the LCD.

6) **UPS failure [ UPS FAIL ](red) [Annunciator: intermittent or constant tones]**

Turned on when an error occurs on the system. In this case, the details of error are indicated on the display panel.

**2.2 Liquid Crystal Display ( 7 in Figure 2.1 )**

The Liquid Crystal Display (LCD) panel indicates the power flow, measured values, operational guidance, data record and error messages. The LCD panel is back-lit to facilitate viewing in different ambient lighting conditions. The LCD will automatically clear if the keyboard is not activated for 3 minutes. The ERROR indicator is cleared after 24 hours and can be reproduced by pressing any key on the panel.

**2.2.1 Menu's**

**A) MAIN MENU (Figure 2.2)**

The LCD panel indicates the power flow, measured values and remote operation mode. The LCD panel shows the power flow. This allows the user to verify the status of the UPS Module.

**FIGURE 2.2 Main screen**

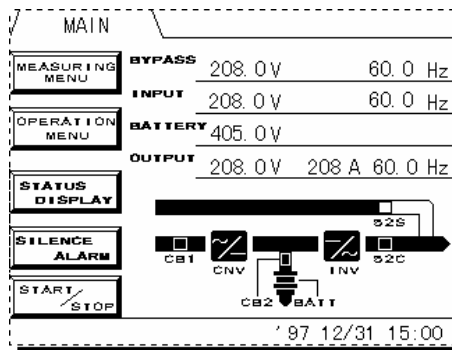

The following will be displayed when the measuring point button on LCD panel is pressed.

**1) Bypass Voltage (Figure 2.3)**

The voltages displayed are the Bypass input voltages (line-to-line) between phases A-B, B-C, C-A and frequency of the Bypass line. Line to neutral voltages A-N, B-N, C-N are measured on 4 wire systems only.

**FIGURE 2.3 Bypass screen**

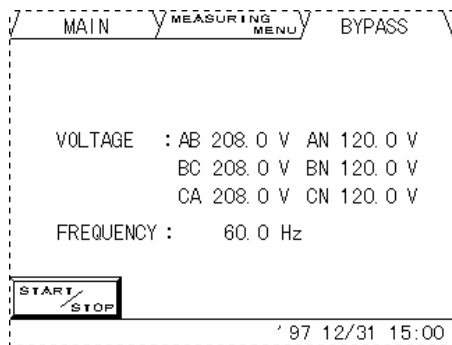

2) Input Voltage and Current (Figure 2.4)

The voltages displayed are the RMS AC input voltages (line-to-line) between phases A-B, B-C C-A and frequency of the AC input line. The RMS values of phases A, B and C currents are also displayed.

**FIGURE 2.4** Input screen

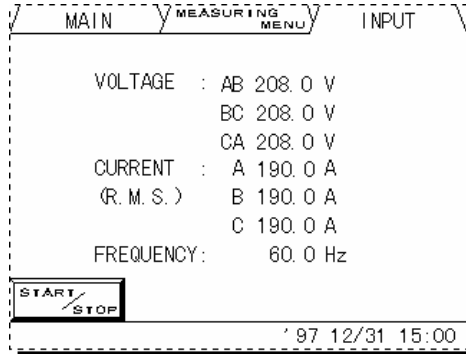

3) Output Voltage, Output Current and Trend Graph

The voltages displayed on the LCD include the inverter output voltages A-B, B-C, C-A. Line to neutral voltages A-N, B-N, C-N are displayed on 4 wire systems only. Inverter output frequency is also displayed. (Figure 2.5)

The currents displayed and the RMS values and Peak Values of Phases A, B, C. N-current (Neutral) is display on a 4 wire system only. (Figure 2.6)

The Trend Graph displays the Effective power values and the Reactive power values. (Figure 2.7)

**FIGURE 2.5** Output voltage screen

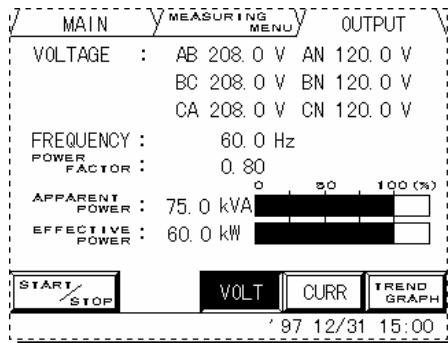

**FIGURE 2.6** Output current screen

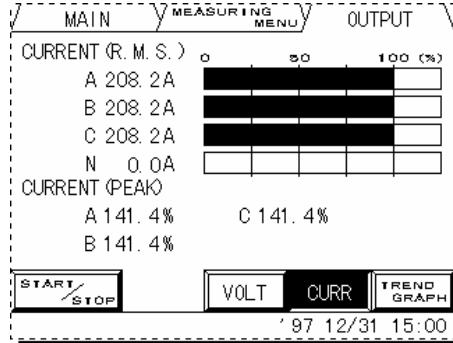

**FIGURE 2.7 Trend graph screen**

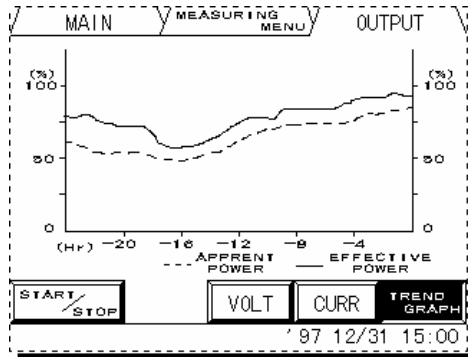

**4) Battery (Figure 2.8)**

This displays the charging, discharging or float mode of the battery, battery current and battery voltage.

**FIGURE 2.8 Battery screen**

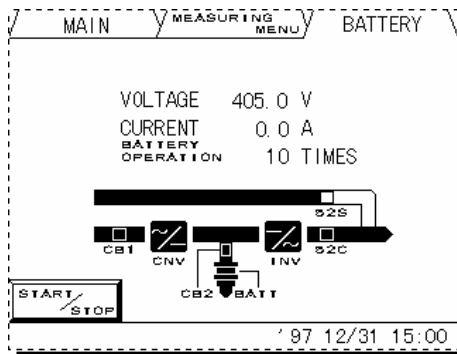

**5) Remote / Local Selection (Figure 2.9)**

The system asks user to select whether the start & stop operation will be performed by a local or remote operation.

**FIGURE 2.9 Remote / Local selection**

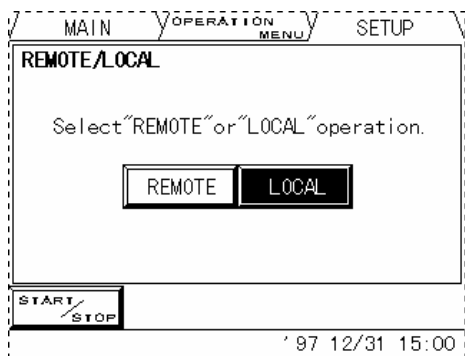

**B) OPERATION MENU** (Figure 2.10)

The following will be displayed when the OPERATION MENU button is pressed on the LCD

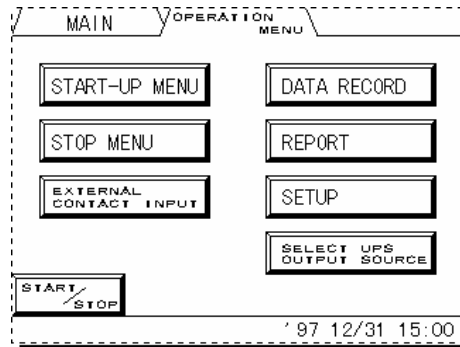
**FIGURE 2.10** Operation menu screen**1) START-UP GUIDANCE**

The display indicates the operation from closing circuit breakers to starting the inverter. When the inverter is started, the display shows the MAIN MENU. When the display changes, the annunciator sounds 3 times requesting user to perform next procedure.

**2) STOP GUIDANCE**

The display indicates the operation of how to stop the inverter and to shutdown the UPS system.

**3) EXTERNAL CONTACT INPUT**

The input of external contacts is indicated by closed or open contacts.

**4) DATA RECORD**

Operation data and events is indicated.

**5) REPORT**

Record data is indicated.

**6) SET UP**

Time, Remote/Local selection and Equalizing charge are set.

**7) SELECT UPS OUTPUT SOURCE**

This display is used to transfer the UPS from inverter to static bypass for maintenance purposes.

**2.2.2 INPUT POWER FAILURE**

During an Input Power Failure the UPS will run on the Batteries. The following will be displayed. The indication of battery operation, load factor, and time remaining.

**FIGURE 2.11 Battery Operation Screen**

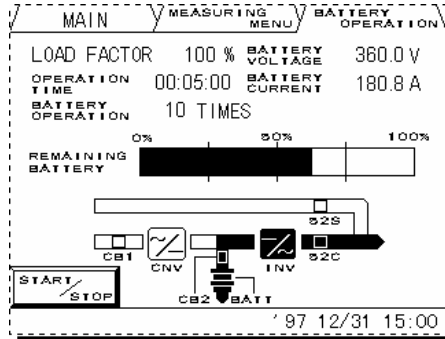

The LCD will display a battery low voltage announcement when battery capacity is near depletion.

**FIGURE 2.12 Battery Low Voltage Screen**

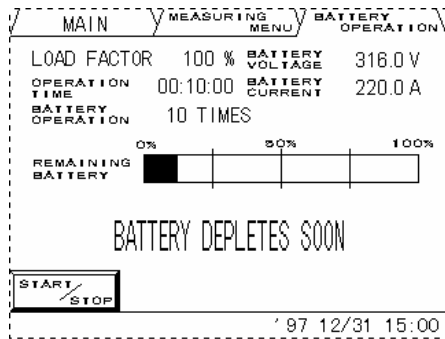

The End of Battery Discharge announcement is displayed when the battery end voltage is reached. At that time, the inverter will perform an electronic shutdown to prevent battery loss of life typical of extreme deep discharge conditions. The inverter will automatically restart to power the load and the batteries will be simultaneously recharged after input power is restored. Details of the End of Battery announcement is shown in Figure 2.13.

**FIGURE 2.13 Discharge Termination Screen**

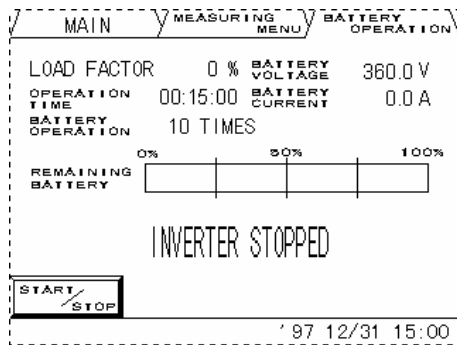

### 2.2.3 FAULT INDICATION (Figure 2.14)

The display shows a fault code, description of fault and a guidance of what action is to take place by the user. A maximum of 10 faults are displayed at the same time.

When an input power failure occurs during the fault Indication, the fault indication and input power failure are alternatively displayed at 5 second intervals.

**FIGURE 2.14** Failure indication screen

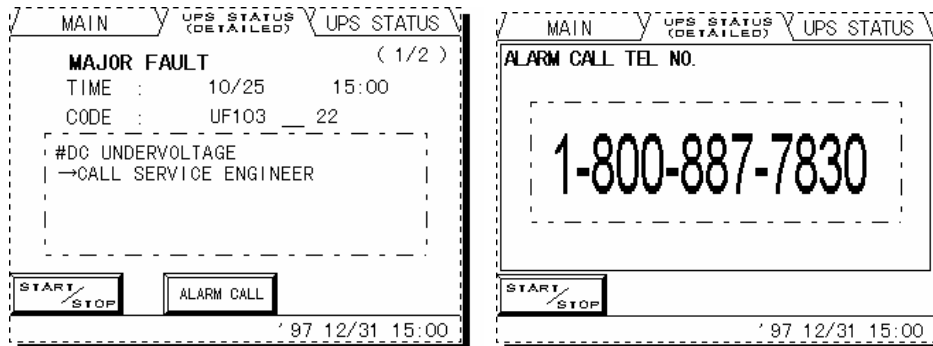

### 2.3 External Signal Terminal Block

The UPS is equipped with a series of input/output terminals for the external annunciation of alarms and the remote access of certain UPS functions. A functional description of the input/output port is presented below. Layout of terminals is shown in Figure 2.15

**FIGURE 2.15** External Signal Terminal Block

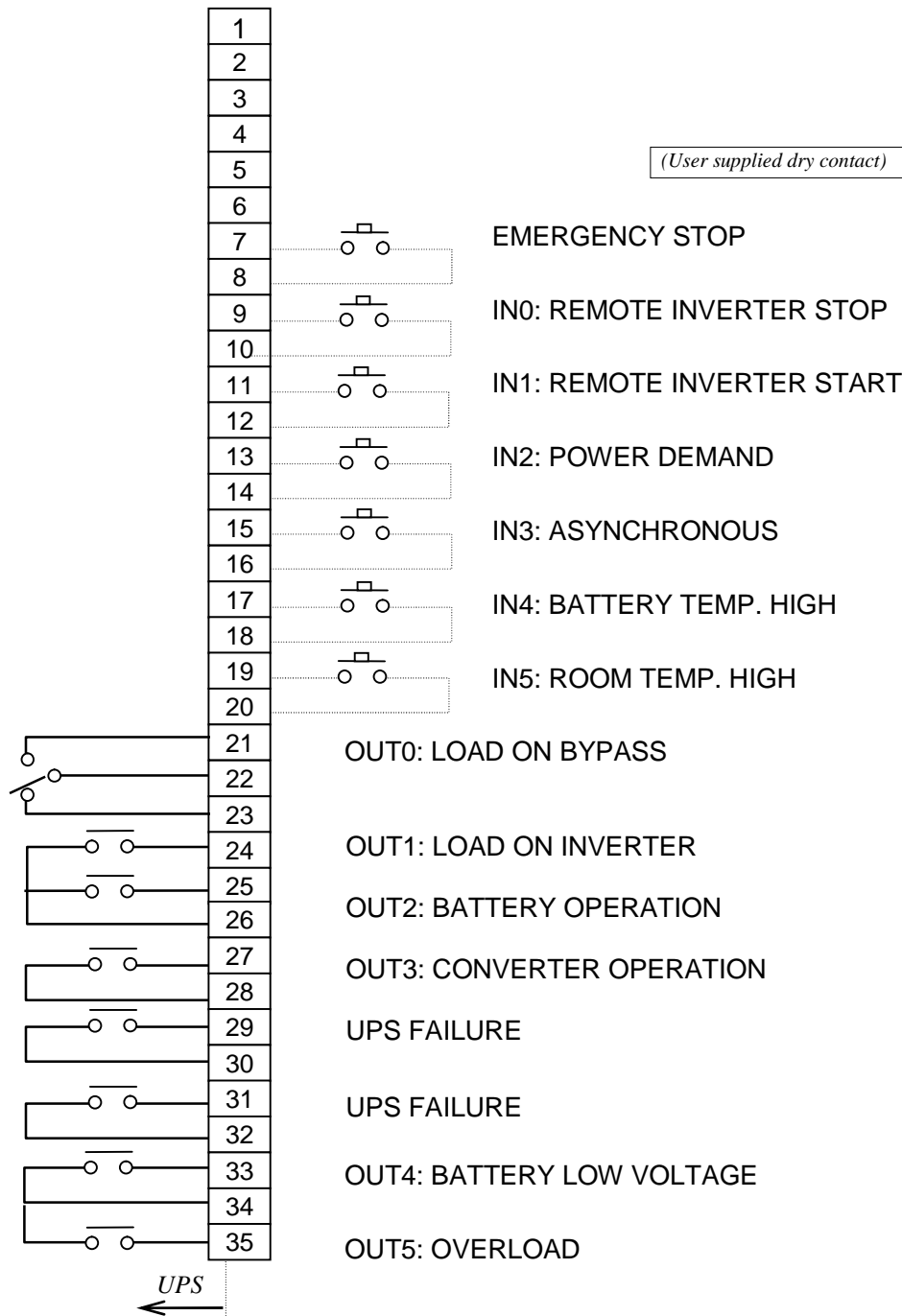

**A) Output Contacts(for external alarm annunciation)**

Output contacts consist of form "A" dry type contacts. Rated value of all output contacts is 120Vac/0.5Aac or 30Vdc/1Adc. Operate all dry contacts at their rated values or lower. Figure 2.16 illustrates typical installation. The external relay can also be a lamp, LED, computer, etc. Connection not to exceed NEC Class 2.

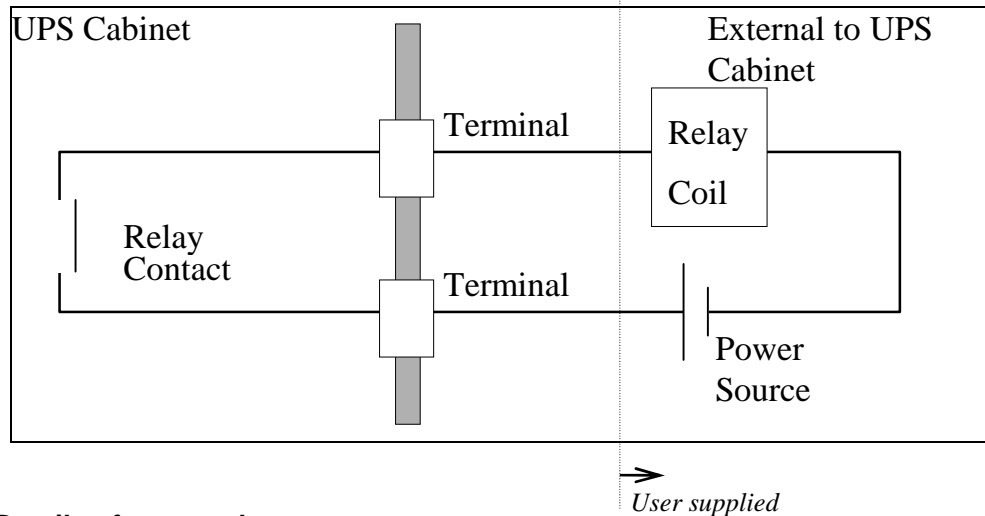
**FIGURE 2.16** Control Wiring for External Contacts

**Details of output alarm contacts :**
**Terminals 22 to 21 "Load on Bypass" contact (OUT0)**

Activated when the power is supplied from the static bypass input.

**Terminals 24 to 26 "Load on Inverter" contact (OUT1)**

Activated when the power is supplied by the inverter.

**Terminals 25 to 26 "Battery Operation" contact (OUT2)**

Activated when the battery is operating following an AC power failure.

**Terminals 27 to 28 "Converter Operation" contact (OUT3)**

Activated when the converter is operating.

**Terminals 29 to 30 "UPS failure" contact**

Activated when a major fault has occurred to the system.

**Terminals 31 to 32 "UPS failure" contact**

Activated when a major fault has occurred to the system.

**Terminals 34 to 33 "Battery Low Voltage" contact (OUT4)**

Activated when DC voltage dropped below discharge end during inverter operation.

**Terminals 35 to 34 "Overload" contact (OUT5)**

Activated when an overload has occurred to the system.



**NOTE:** *The UPS is equipped with a selectable output contact feature. The above alarms are the default settings. Contact **MITSUBISHI ELECTRIC POWER PRODUCTS, INC.** for set-up information.*

### B) Input Contacts(for remote access of UPS)

External contacts are provided by the user of the UPS system. Terminal voltage at the UPS is 24Vdc. Provide external dry contact accordingly.



**CAUTION:** *Do not apply voltage to remote access input terminals. Damage to UPS may result.*

Refer to Figure 2.17 for typical wiring configuration. Although this figure applies to the remote start/stop terminals, the same wiring arrangement is used for emergency stop; asynchronous command; power demand; battery temperature high.

**FIGURE 2.17** Remote "Start" Contact Connections

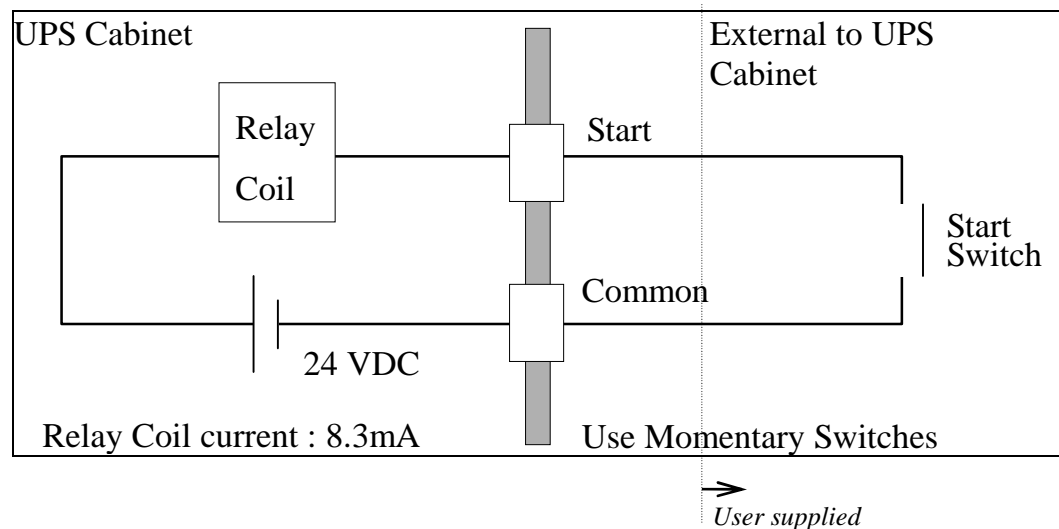

#### Details of input contacts for remote access :

##### Terminals 7 to 8 "Emergency Stop" contact input

Used to perform a remote UPS emergency power off (EPO).

*The load will be dropped.*

##### Terminals 9 to 10 Remote "Inverter Stop" input terminal (IN0)

Used to stop inverter from a remote location. UPS must be programmed for remote operation. Refer to Operations Menu for procedure.

##### Terminals 11 to 12 Remote "Inverter Start" input terminal (IN1)

Used to start inverter from a remote location. UPS must be programmed for

remote operation. Refer to Operations Menu for procedure.

Terminals 13 to 14 **"Power Demand Command" contact input (IN2)**

Used to control the input current limit to the UPS converter (usually during generator operation). Power demand is turned ON when the contact is closed. Power demand is turned OFF when the contact is open.

Terminals 15 to 16 **"Asynchronous Command" contact input (IN3)**

Used to create an asynchronous condition between the static bypass source and the inverter. Asynchronous condition is enabled when the switch is closed. Asynchronous condition is disabled when the switch is opened.

Terminals 17 to 18 **"BATTERY TEMP. HIGH" contact input (IN4)**

Input fed by a thermocouple that monitors battery temperature. The converter float voltage level is reduced for battery over-temperature conditions. External thermocouple is user supplied

Terminals 19 to 20 **"ROOM TEMP. HIGH" contact input (IN5)**

Input fed by a thermocouple that monitors room temperature. External thermocouple is user supplied.



**NOTE :** *In all cases, a switch having a plate is recommended in order to reduce possibility of accidental operation.*

## 2.4 External communication connector

This is a RS232C port for "DiamondLink" monitoring software. The layout of connector is shown in Figure 2.18. Connections not to exceed NEC Class 2.

**FIGURE 2.18** External communication connector

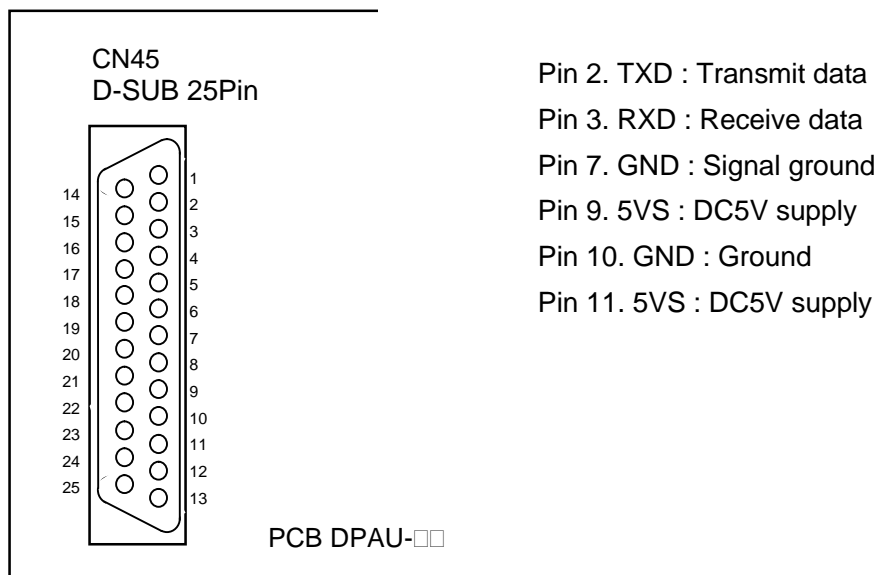

### 3.0 INSTALLATION AND OPERATION

#### 3.1 Transportation and Installation

**TABLE 3.1** How to transport and install the system

Transportation	Installation
Transport unit with forklift. Use eye bolts (supplied) to carry with overhead crane.	Using the holes (4 - 24) pre drilled into the UPS channel base, anchor the unit using appropriate hardware.



**Note :** *Do not transport in a horizontal position. Cabinets should be maintained upright within +/- 15° during handling.*

#### 3.2 Installation Procedure

**A) Note the load tolerance of the floor**

Refer to Table 3.2 for list of weights of UPS's.

**TABLE 3.2** List of UPS weights

UPS Capacity (kVA)	30	40	50	75
Weight (lb.)	1050	1450	1470	1700

**B) Minimum clearance required for ventilation**

Right side ..... 1.0" (25 mm) (not required when sidecars are used)  
 Left side ..... 1.0" (25 mm) (not required when sidecars are used)  
 Back side ..... 0.0" (0.0 mm)  
 Top side ..... 23.6" (600 mm) (for air flow)

**C) Space requirement for routine maintenance**

Allow the following space at the time of installation.

Front ..... 39.4" (1000 mm)  
 Sides ..... 0.0" (0.0 mm)  
 Rear ..... 0.0" (0.0 mm)

## D) External Battery Supply

Please refer to the following when installing batteries:

1. The customer shall make reference to the battery manufacturer's installation manual for battery installation and maintenance instructions.
2. The maximum permitted fault current from the remote battery supply and the DC voltage rating of the battery supply over-current protective device are shown in Table 3.3.

**TABLE 3.3** Maximum Permitted Fault Current

UPS CAPACITY (kVA)	DC VOLTAGE RATING (V)	MAXIMUM FAULT CURRENT (A)
30	360	25,000
40	360	30,000
50	360	30,000
75	360	30,000

### 3.3 Procedure for Cable Connections

- I. Confirm the capacity of the UPS being installed. Identify the input/output power terminal blocks as shown in the appropriate Figure 3.1 through Figures 3.2-a~b.
- II. Connect the grounding conductor from the input service entrance to the UPS ground bar and associated equipment per the National Electric Code (NEC) and applicable codes per authority having jurisdiction (AHJ).
- III. Connect Input Power Cables:

For configurations which utilize an input transformer connect cables from the input service entrance to the input transformer power terminals identified as H1, H2, H3 in figures 3.3-c~m. Refer to Table 3.4.b for recommended cable sizes.



**Note:** *When Bypass Input is fed by an input transformer the requirement for Bypass Input circuit breaker (Warning 2) can be met with circuit breaker (MCCB) on the primary side of the transformer.*

1. Two (2) sources feeding the UPS:
  - A. Connect the converter input power cables from either 1) input service entrance, or 2) input transformer power terminals identified as X1, X2, X3 to the converter

input power terminals identified as A10, B10, C10 in Figures 3.2-a~b and Figures 3.3-a~m. Input cables must be sized for an ampacity larger than the maximum input drawn by the converter. Refer to Table 3.4.a for recommended cable sizes.

- B. Confirm that an external bypass input circuit breaker (MCCB) is installed (refer to WARNING 2). Connect the bypass input power cables from the input service entrance to the bypass input power terminals identified as A30, B30, C30 and N60 in Figures 3.2-a~b and Figures 3.3-a~m. Bypass input cables must be sized for an ampacity larger than the maximum output current capacity of the UPS. Refer to Table 3.4 a for recommended cable sizes.

- 2. One (1) source feeding the UPS:



**Note:** *When utilizing an output transformer the neutral is not required for the Bypass Input. The neutral for the load will be generated at the secondary of the output transformer. Refer to Figures 3.3-h and 3.3-m.*

- A. Confirm that an external input circuit breaker sized to protect both the converter input and the bypass lines is installed. Consult equipment nameplate for current ratings. Connect the bypass input power cables from either 1) input service entrance, or 2) input transformer power terminals identified as X1, X2, X3 and X0 to the bypass input power terminals identified as A30, B30, C30 and N60 in Figures 3.2-a~b and Figures 3.3-a~m. Input cables must be sized for an ampacity larger than the maximum current capacity of the UPS. Refer to Table 3.4.a. "Input Side" for recommended cable sizes.
- B. Using adequately sized conductors per Table 3.4.a "Input Side" and referring to the appropriate figure identified in Figures 3.2-a~b and Figures 3.3-a~l, jumper bypass terminals A30, B30, C30 to converter input terminals A10, B10, C10.

3. For configurations that utilize an Input Trans/MBP Combination Cabinet:
  - A. Connect the bypass input power cables from Bypass Input Isolation Breaker (MBP SW1) Terminals A, B and C to the UPS bypass input power terminals identified as A30, B30 and C30. Connect Input Transformer/MBP Neutral to UPS Terminal N60. Refer to Figures 3.2-a~b and Figure 3.3.e. Bypass input cables must be sized for an ampacity larger than the maximum input current drawn by the UPS converter. Refer to Table 3.4.a "Input Side" for recommended cable sizes.
  - B. Using adequately sized conductors per Table 3.4.a "Input Side" and referring to the appropriate figure identified in Figures 3.2-a~b and Figure 3.3.e, jumper bypass terminals A30, B30, C30 to converter input terminals A10, B10, C10.
  
- IV. Connect Output Power Cables:
  1. Referring to Figures 3.2-a~b connect UPS load terminals A60, B60, C60 and N60 to load distribution panel. Refer to Table 3.4.a for cable sizes.
  
  2. For configurations that utilize an output transformer, connect UPS load terminals identified as A60, B60 and C60 to output transformer power terminals identified as X1, X2 and X3. Refer to Table 3.4.a "Output Side" at 208V for cable size. Connect output transformer power terminals identified as H1, H2, H3 and H0 to load distribution panel. Refer to Figures 3.2-a~b and Figures 3.3-h and 3.3-m. Refer to Table 3.4.b for cable size.
  
  3. For configurations which utilize an Input Transformer/MBP Combo Cabinet, connect UPS load terminals identified as A60, B60 and C60 to UPS Output Isolation Breaker (MBP SW3) Terminals A, B and C. Connect MBP Load Terminals A, B, C and neutral to load distribution panel. Refer to Figures 3.2-a~b and Figure 3.3.e. Refer to Table 3.4.a "Output Side" at 208V for cable size.
  
- V. Connect external signal terminal block as needed. Refer to section 2.3 and Figure 2.15 for functional description. 12 AWG, or less, shielded conductor is recommended.



- NOTES:**
- 1. Confirm that all UPS internal contactors (breakers) "CB1", "CB2", and "CB3" are open before energizing UPS.*
  - 2. UPS power terminals are supplied with stud type fittings. It is recommended that compression lugs be used to fasten all UPS input/output power cables. Refer to Table 3.5.a for recommended compression lugs and appropriate crimping tool.*
  - 3. Transformer terminals are stud type fittings with 2 hole NEMA pattern. It is recommended that compression lugs be used to fasten all transformer field installed power cables. Refer to Table 3.5.b for recommended compression lugs and appropriate crimping tool.*
  - 4. Input Trans/MBP Breakers are equipped with mechanical terminals for field connections.*
  - 5. If three-wire source for input and bypass input is utilized, the neutral conductor in the UPS must be bonded to ground.*

**Table 3.4.a Recommended cable size and torque requirements (for UPS)**

UPS Capacity (kVA)	Input Side * 1, 2		Output Side * 1, 2		Bypass Side * 1, 2		DC Input Side * 1, 2	
	Cable Size	Torque (in. lbs)	Cable Size	Torque in. lbs	Cable Size	Torque in. lbs	Cable Size	Torque in. lbs
30kVA (208V)	1 AWG or larger	100-135 in. lbs	1 AWG or larger	100-135 in. lbs	1 AWG or larger	100-135 in. lbs	4 AWG or larger	100-135 in. lbs
30kVA (480V)	1 AWG or larger	100-135 in. lbs	8 AWG or larger	100-135 in. lbs	8 AWG or larger	100-135 in. lbs	4 AWG or larger	100-135 in. lbs
30kVA (600V)	1 AWG or larger	100-135 in. lbs	8 AWG or larger	100-135 in. lbs	8 AWG or larger	100-135 in. lbs	4 AWG or larger	100-135 in. lbs
40kVA (208V)	1/0 AWG or larger	200-269 in. lbs	1/0 AWG or larger	100-135 in. lbs	1/0 AWG or larger	100-135 in. lbs	2 AWG or larger	200-269 in. lbs
40kVA (480V)	1/0 AWG or larger	200-269 in. lbs	4 AWG or larger	100-135 in. lbs	4 AWG or larger	100-135 in. lbs	2 AWG or larger	200-269 in. lbs
40kVA (600V)	1/0 AWG or larger	200-269 in. lbs	6 AWG or larger	100-135 in. lbs	6 AWG or larger	100-135 in. lbs	2 AWG or larger	200-269 in. lbs
50kVA (208V)	2/0 AWG or larger	200-269 in. lbs	2/0 AWG or larger	100-135 in. lbs	2/0 AWG or larger	100-135 in. lbs	1/0 AWG or larger	200-269 in. lbs
50kVA (480V)	2/0 AWG or larger	200-269 in. lbs	3 AWG or larger	100-135 in. lbs	3 AWG or larger	100-135 in. lbs	1/0 AWG or larger	200-269 in. lbs
50kVA (600V)	2/0 AWG or larger	200-269 in. lbs	4 AWG or larger	100-135 in. lbs	4 AWG or larger	100-135 in. lbs	1/0 AWG or larger	200-269 in. lbs
75kVA (208V)	350MCM or larger	347-469 in. lbs	350 MCM or larger	347-469 in. lbs	350 MCM or larger	347-469 in. lbs	4/0 AWG or larger	347-469 in. lbs
75kVA (480V)	350MCM or larger	347-469 in. lbs	1 AWG or larger	347-469 in. lbs	1 AWG or larger	347-469 in. lbs	4/0 AWG or larger	347-469 in. lbs
75kVA (600V)	350MCM or larger	347-469 in. lbs	3 AWG or larger	347-469 in. lbs	3 AWG or larger	347-469 in. lbs	4/0 AWG or larger	347-469 in. lbs

\*1 - Voltage drop across power cables not to exceed 2% of nominal source voltage.

\*2 - Allowable capacities based on 75 °C insulation at an ambient temperature of 30 °C. Not more than 3 conductors in a raceway without de-rating.

**Table 3.4.b** Recommended cable size and torque requirements  
(input and output transformer field connections)

UPS Capacity (kVA)	Input Transformer *1,2			Output Transformer *1,2			
	Primary Voltage	Recommended Breaker (A)	Cable Size	Torque (in. lbs)	Secondary Voltage	Cable Size	Torque in. lbs
30kVA	480V	50	6 AWG or larger	60 in. lbs	480V	6 AWG or larger	60 in. lbs
30kVA	600V	40	6 AWG or larger	60 in. lbs	600V	6 AWG or larger	60 in. lbs
40kVA	480V	70	4 AWG or larger	144 in. lbs	480V	4 AWG or larger	144 in. lbs
40kVA	600V	50	6 AWG or larger	144 in. lbs	600V	6 AWG or larger	144 in. lbs
50kVA	480V	80	3 AWG or larger	144 in. lbs	480V	3 AWG or larger	144 in. lbs
50kVA	600V	70	4 AWG or larger	144 in. lbs	600V	4 AWG or larger	144 in. lbs
75kVA	480V	125	1 AWG or larger	144 in. lbs	480V	1 AWG or larger	144 in. lbs
75kVA	600V	100	3 AWG or larger	144 in. lbs	600V	3 AWG or larger	144 in. lbs

\*1 - Voltage drop across power cables not to exceed 2% of nominal source voltage.

\*2 - Allowable capacities based on 75 °C insulation at an ambient temperature of 30 °C. Not more than 3 conductors in a raceway without de-rating.

**TABLE 3.5a** Crimp Type Compression Lug (UPS)

WIRE SIZE  (CODE)	WIRE STRAND  CLASS	RECOMMENDATION		CRIMP TOOL REQUIRED BURNDY TYPE Y35 OR Y46	
		VENDOR	CAT. NO.	COLOR KEY	DIE INDEX
8	B	BURNDY ILSCO	YA8C-TC14 -----	RED -----	49 -----
	I	BURNDY	YA8C-LB	-----	1013
6	B	BURNDY	YA6C	BLUE	7 / 374
	B/I I	ILSCO BURNDY	CRB-6L YA5C-LB	BLUE -----	7 / 374 1014
4	B	BURNDY	YA4C	GRAY	8 / 346
	B/I I	ILSCO BURNDY	CRB-4L YA3C-LB	GRAY -----	8 / 346 1016
3	B	BURNDY	YA3C	WHITE	9
	B I	ILSCO BURNDY	CRA-3L YA2C-LB	WHITE -----	9 1017
2	B	BURNDY	YA2C	BROWN	10
	B I	ILSCO BURNDY	CRB-2L YA1C-LB	BROWN -----	10 1018
1	B	BURNDY	YA1C	GREEN	11 / 375
	B I	ILSCO BURNDY	CRA-1L YA25-LB	GREEN -----	11 / 375 1019
1/0	B	BURNDY	YA25	PINK	12 / 348
	B I	ILSCO BURNDY	CRA-1/OL YA26-LB	PINK -----	12 / 348 1020
2/0	B	BURNDY	YA26	BLACK	13
	B I	ILSCO BURNDY	CRA-2/OL YA27-LB	BLACK -----	13 1021
3/0	B	BURNDY	YA27	ORANGE	14 / 101
	B I	ILSCO BURNDY	CRB-3/OL YA28-LB	ORANGE -----	14 / 101 1022
4/0	B	BURNDY	YA28	PURPLE	15
	B I	ILSCO BURNDY	CRB-4/OL YA29-LB	PURPLE -----	15 1023
250 MCM	B	BURNDY	YA29	YELLOW	16
	B I	ILSCO BURNDY	CRA-250L YA30-LB	YELLOW -----	16 1024
300 MCM	B	BURNDY	YA30-L7	WHITE	17 / 298
	B I	ILSCO BURNDY	CRA-300L YA32-LB	WHITE -----	17 / 298 1026
350 MCM	B	BURNDY	YA31-L7	RED	18 / 324
	B I	ILSCO BURNDY	CRA-350L YA34-LB	RED -----	18 / 324 1027



*When using crimp type lugs, the lugs should be crimped to the specifications  
e manufacturer's instructions for both crimp tool and lug.*

**TABLE 3.5.b** Crimp Type Compression Lug (Transformer Field Terminations)

WIRE SIZE  (CODE)	WIRE STRAND  CLASS	RECOMMENDATION		CRIMP TOOL REQUIRED BURNDY TYPE Y35 OR Y46	
		VENDOR	CAT. NO.	COLOR KEY	DIE INDEX
8	B	BURNDY	-----	-----	-----
		ILSCO	-----	-----	-----
	I	BURNDY	-----	-----	-----
6	B	BURNDY	YA6C-2LN	BLUE	7 / 374
	B	ILSCO	-----	-----	-----
	B	BURNDY	YA6C-2N	BLUE	7 / 374
4	B	BURNDY	YA4C-2LN	GRAY	8 / 346
	B/I	ILSCO	CRC-4L2	GRAY	8 / 346
	I	BURNDY	-----	-----	-----
3	B	BURNDY	YA3C-2N	WHITE	9
		ILSCO	-----	-----	-----
	I	BURNDY	-----	-----	-----
2	B	BURNDY	YA2C-2LN	BROWN	10
	B	ILSCO	CRC-2L2	BROWN	10
	B	BURNDY	YA2C-2N	BROWN	10
1	B	BURNDY	YA1C-2LN	GREEN	11 / 375
	B/I	ILSCO	CRC-1L2	GREEN	11 / 375
	B	BURNDY	YA1C-2N	GREEN	11 / 375



**NOTE:** *When using crimp type lugs, the lugs should be crimped to the specifications given in the manufacturer's instructions for both crimp tool and lug.*

**FIGURE 3.1** UPS Terminal Designation

**Table 3.6** Wiring configuration

Figure	Input Voltage	Output Voltage	One feed / Two feed	Input Transformer	Output Transformer	MBS*
3.3 a	208	208	Two	-	-	-
3.3 b	208	208	One	-	-	-
3.3 c	480	208	Two	O	-	-
3.3 d	480	208	One	O	-	-
3.3 e	480	208	One	O	-	O
3.3 f	480	480	Two	O	-	-
3.3 g	480	480	One	O	-	-
3.3 h	480	480	One	O	O	-
3.3 i	600	208	Two	O	-	-
3.3 j	600	208	One	O	-	-
3.3 k	600	600	Two	O	-	-
3.3 l	600	600	One	O	-	-
3.3 m	600	600	One	O	O	-

\*MBS: Maintenance Bypass Switch

**FIGURE 3.2 a** Input/Output Power Terminals (40 kVA, 50 kVA, 75 kVA UPS)

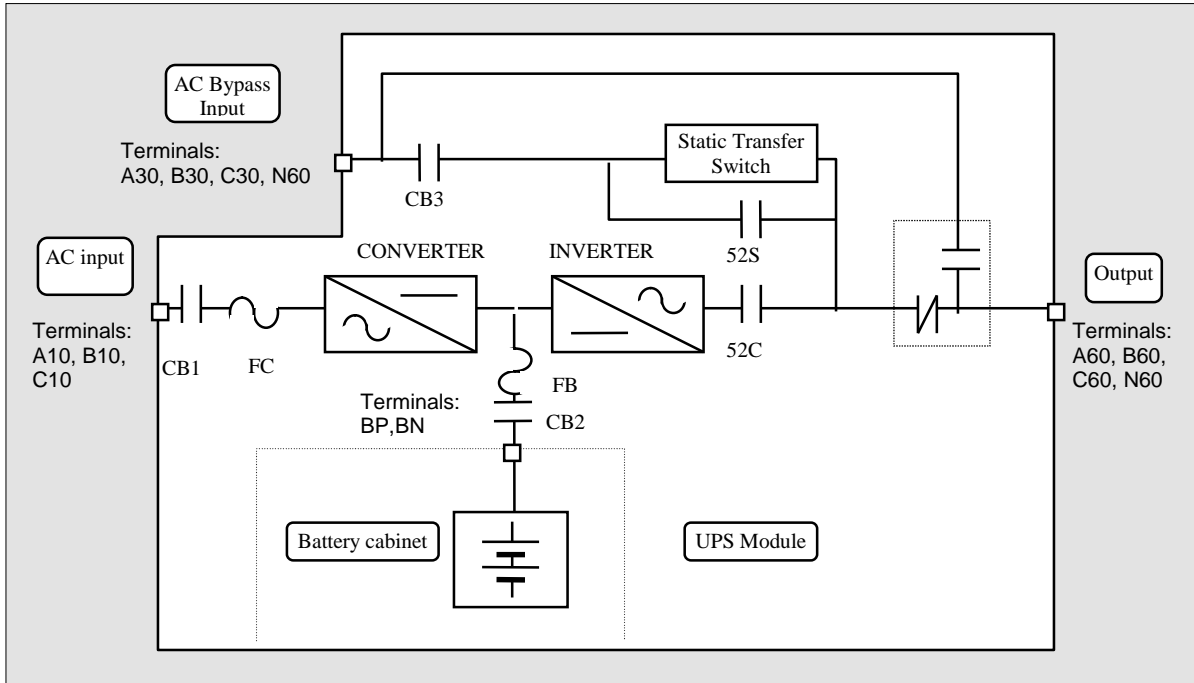
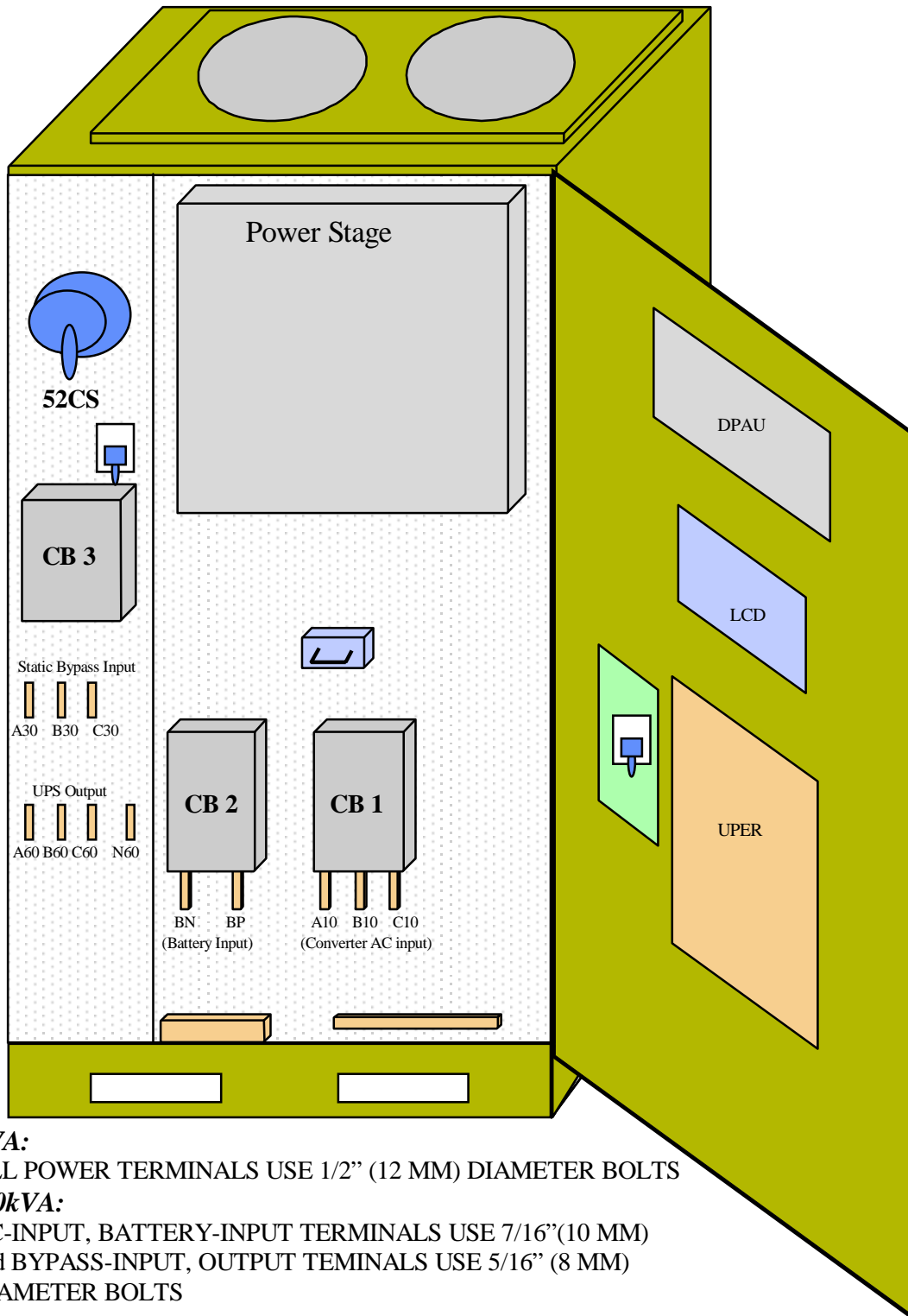

**75kVA:**

ALL POWER TERMINALS USE 1/2" (12 MM) DIAMETER BOLTS

**40/50kVA:**

AC-INPUT, BATTERY-INPUT TERMINALS USE 7/16"(10 MM)  
and BYPASS-INPUT, OUTPUT TERMINALS USE 5/16" (8 MM)  
DIAMETER BOLTS

**FIGURE 3.2 b** Input/Output Power Terminals (30 kVA UPS)

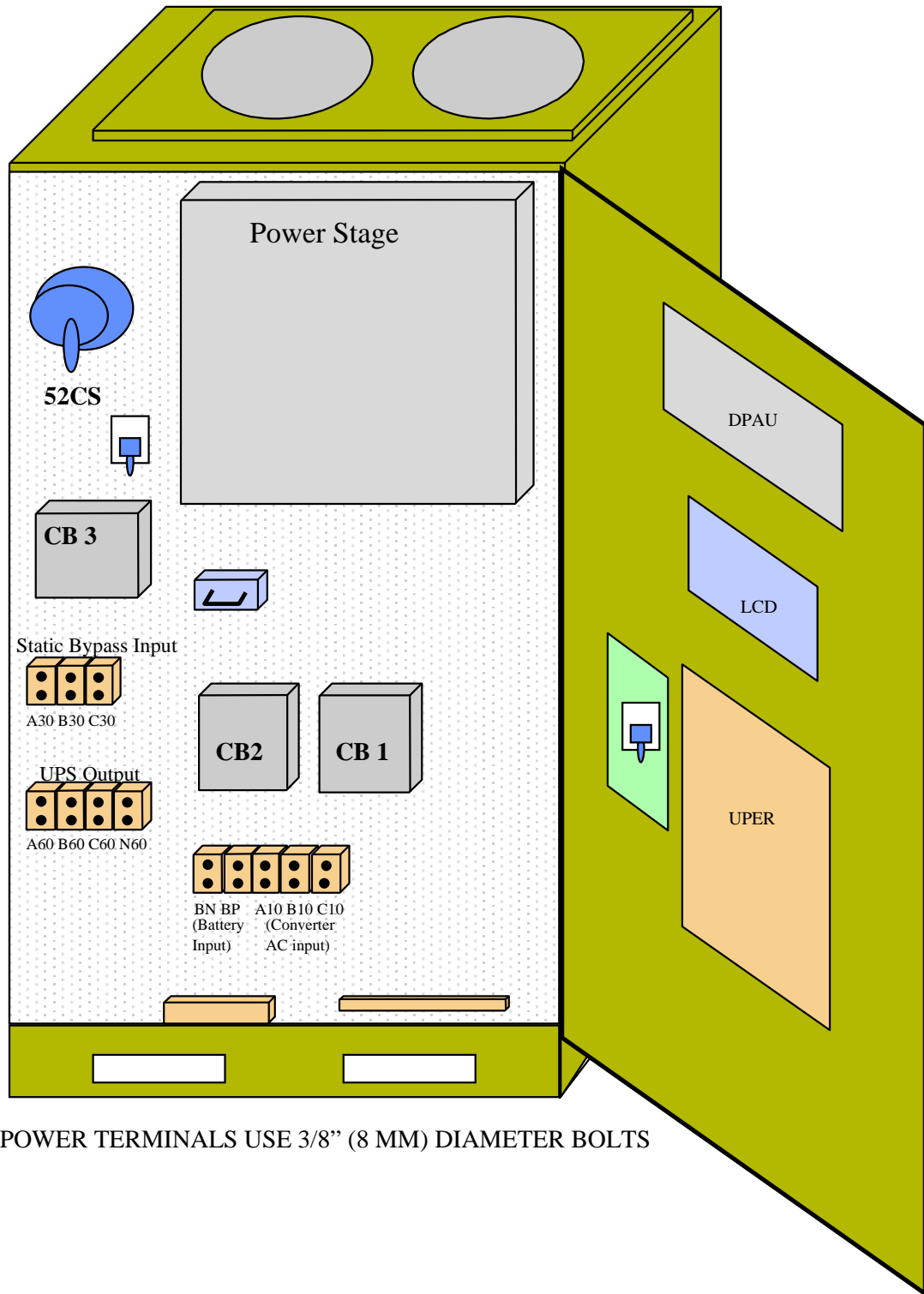

ALL POWER TERMINALS USE 3/8" (8 MM) DIAMETER BOLTS

**FIGURE 3.3 a** Wiring configuration for 208V input / 208V output. (Two sources feeding the UPS)

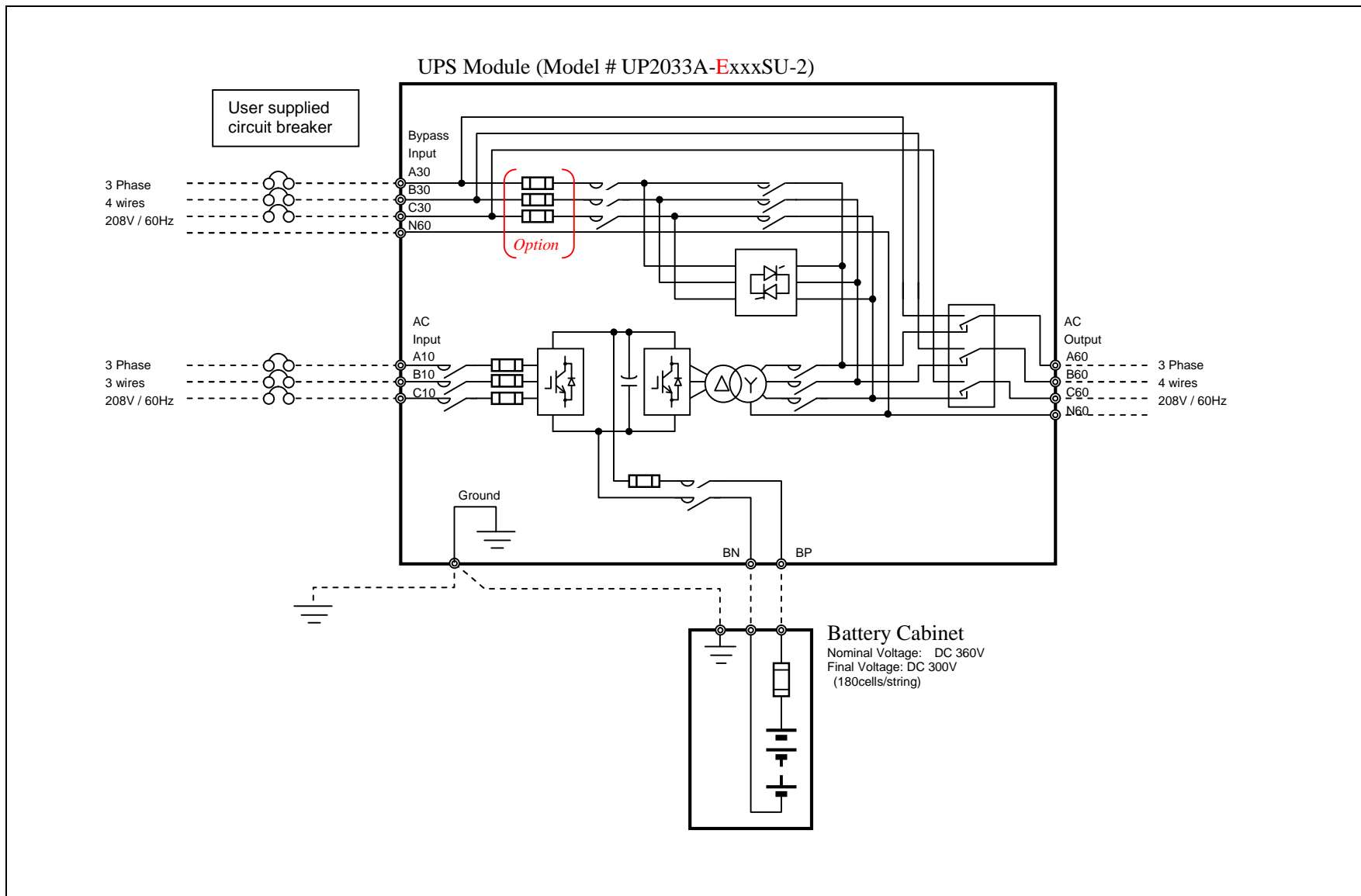

**FIGURE 3.3 b** Wiring configuration for 208V input / 208V output. (One sources feeding the UPS)

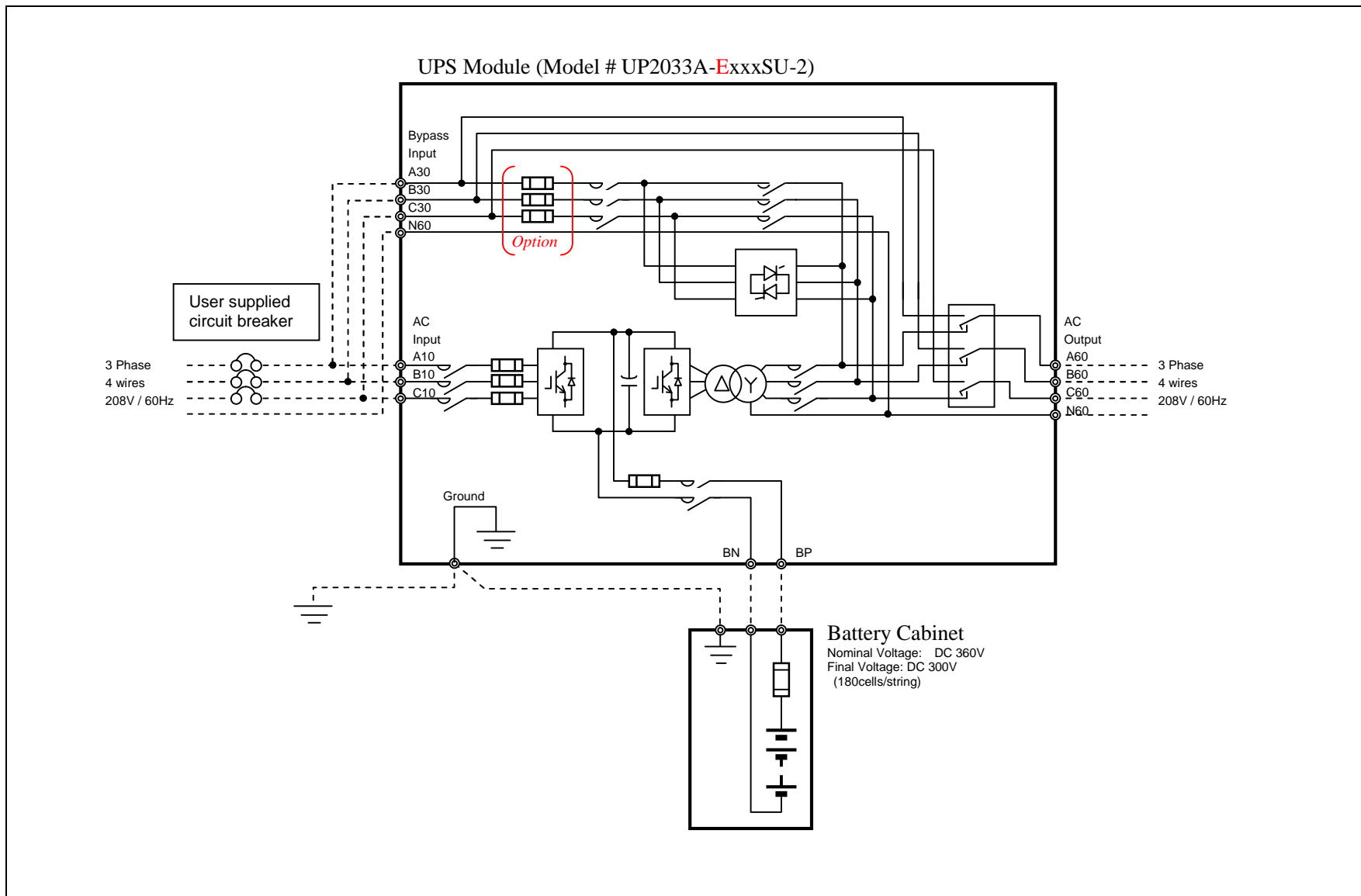
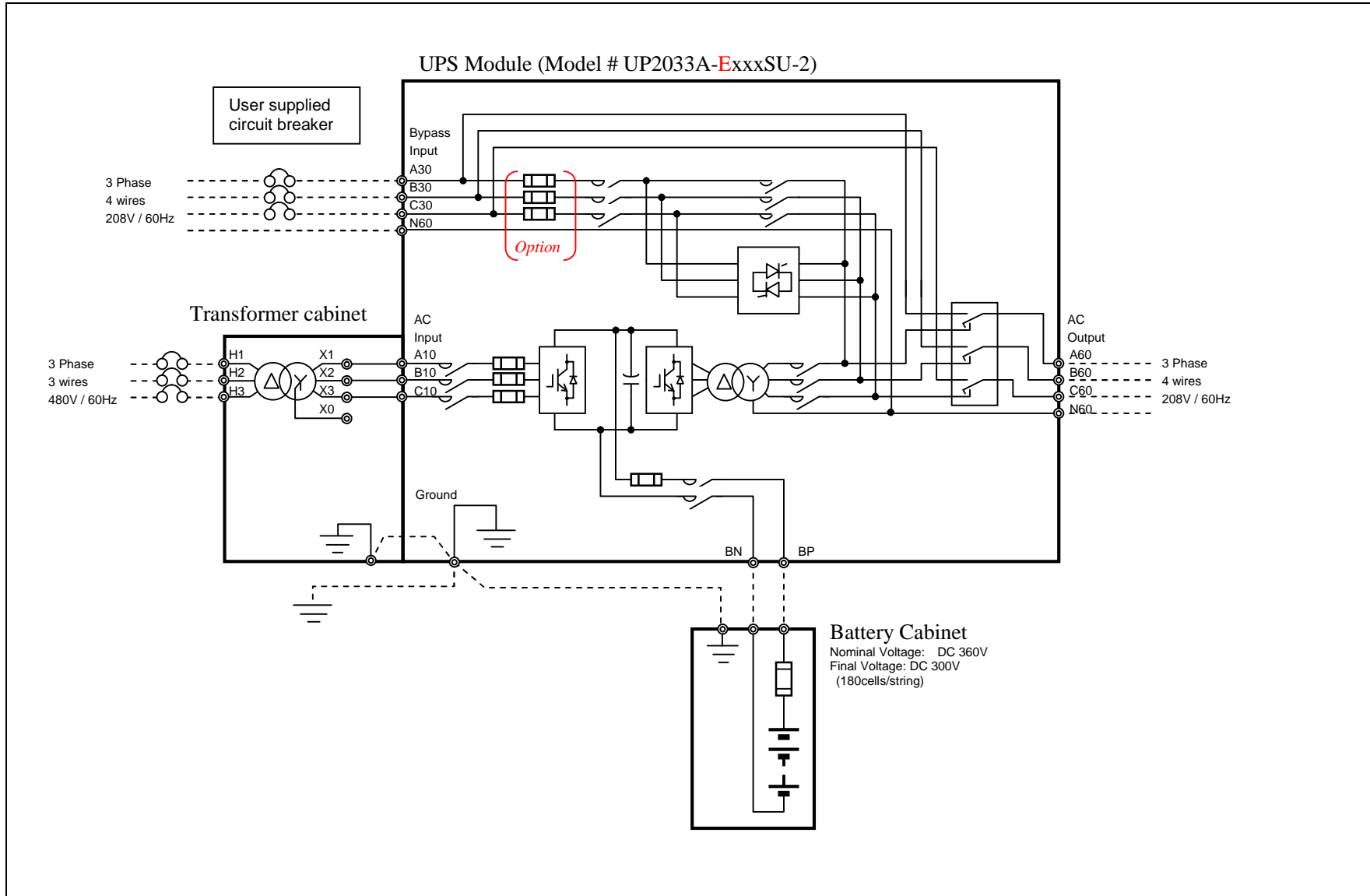
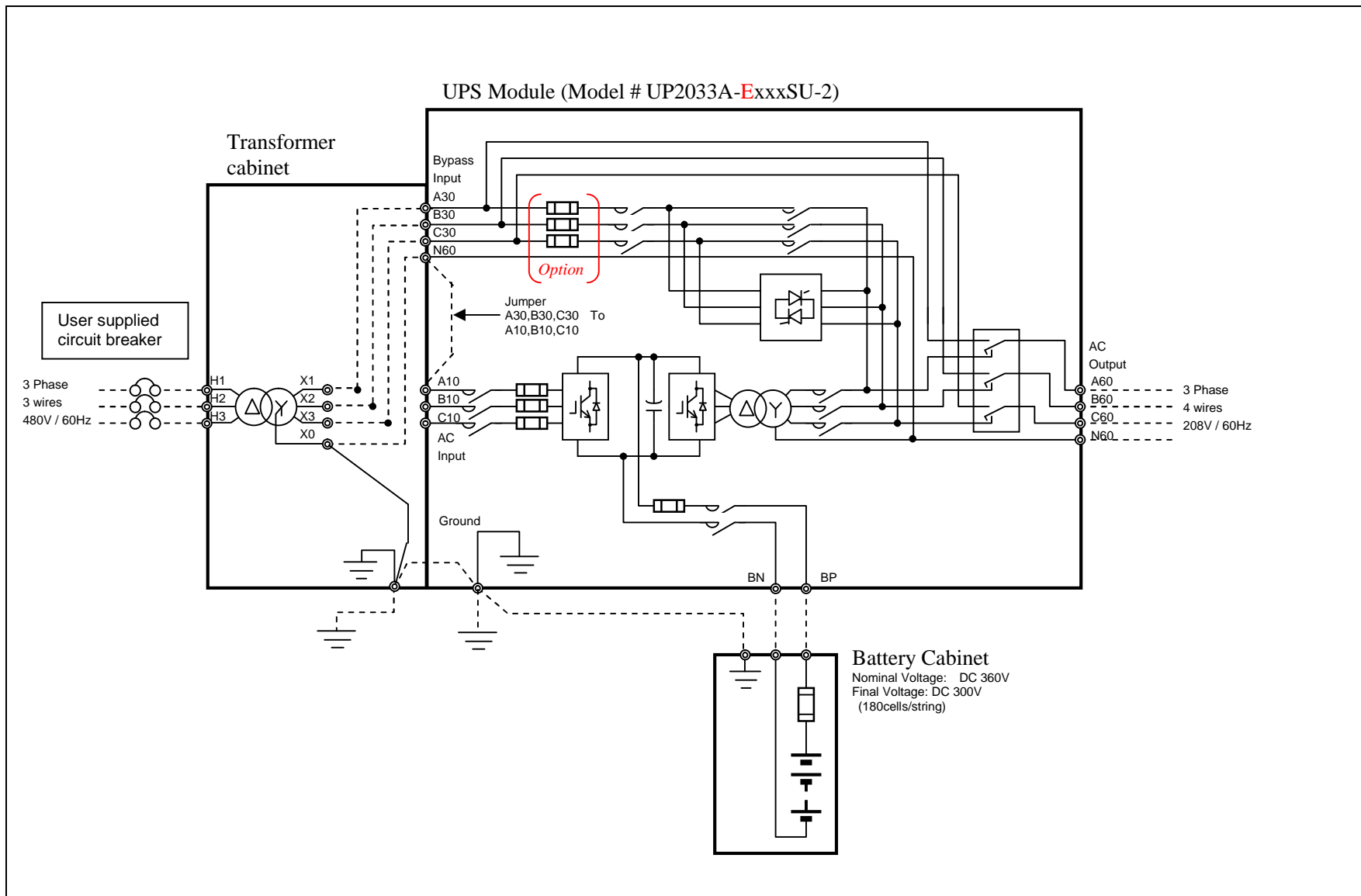



FIGURE 3.3 c Wiring configuration for 480V input / 208V output. (Two sources feeding the UPS)



**FIGURE 3.3 d** Wiring configuration for 480V input / 208V output. (One sources feeding the UPS)



**FIGURE 3.3 e** Wiring configuration for 480V input / 208V output. (One sources feeding the UPS)

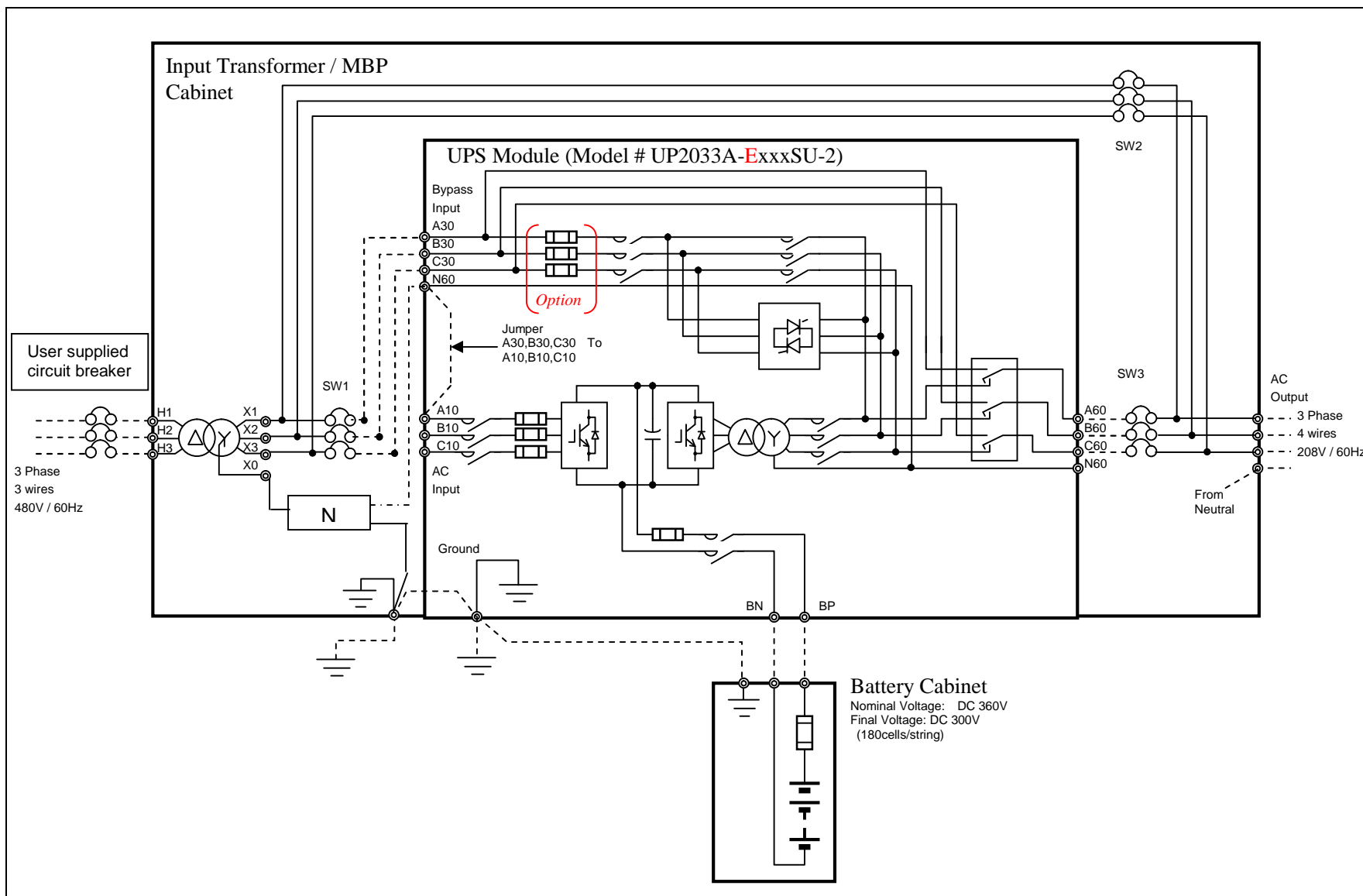

**FIGURE 3.3 f** Wiring configuration for 480V input / 480V output. (Two sources feeding the UPS)

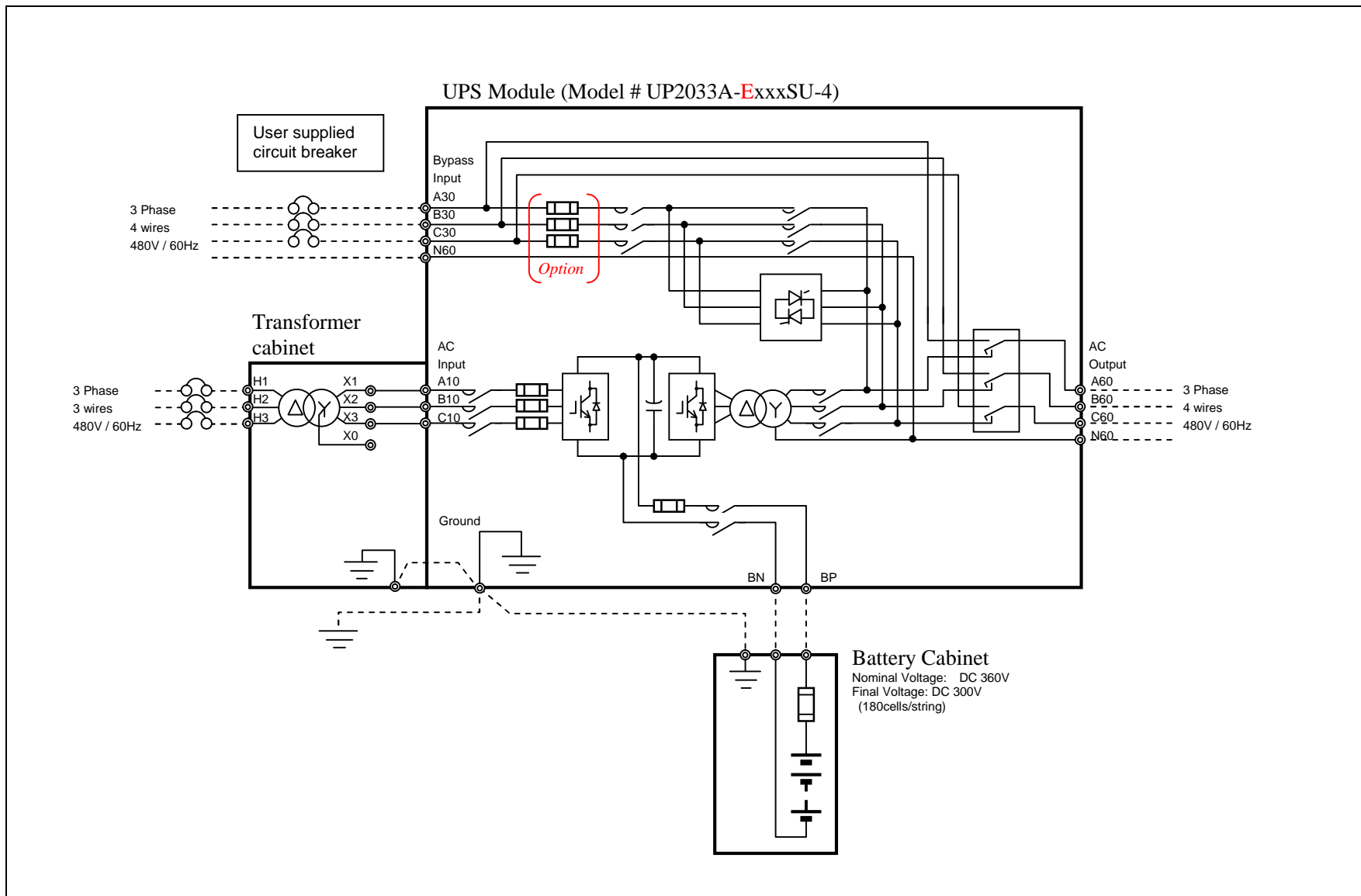

**FIGURE 3.3 g** Wiring configuration for 480V input / 480V output. (One sources feeding the UPS)

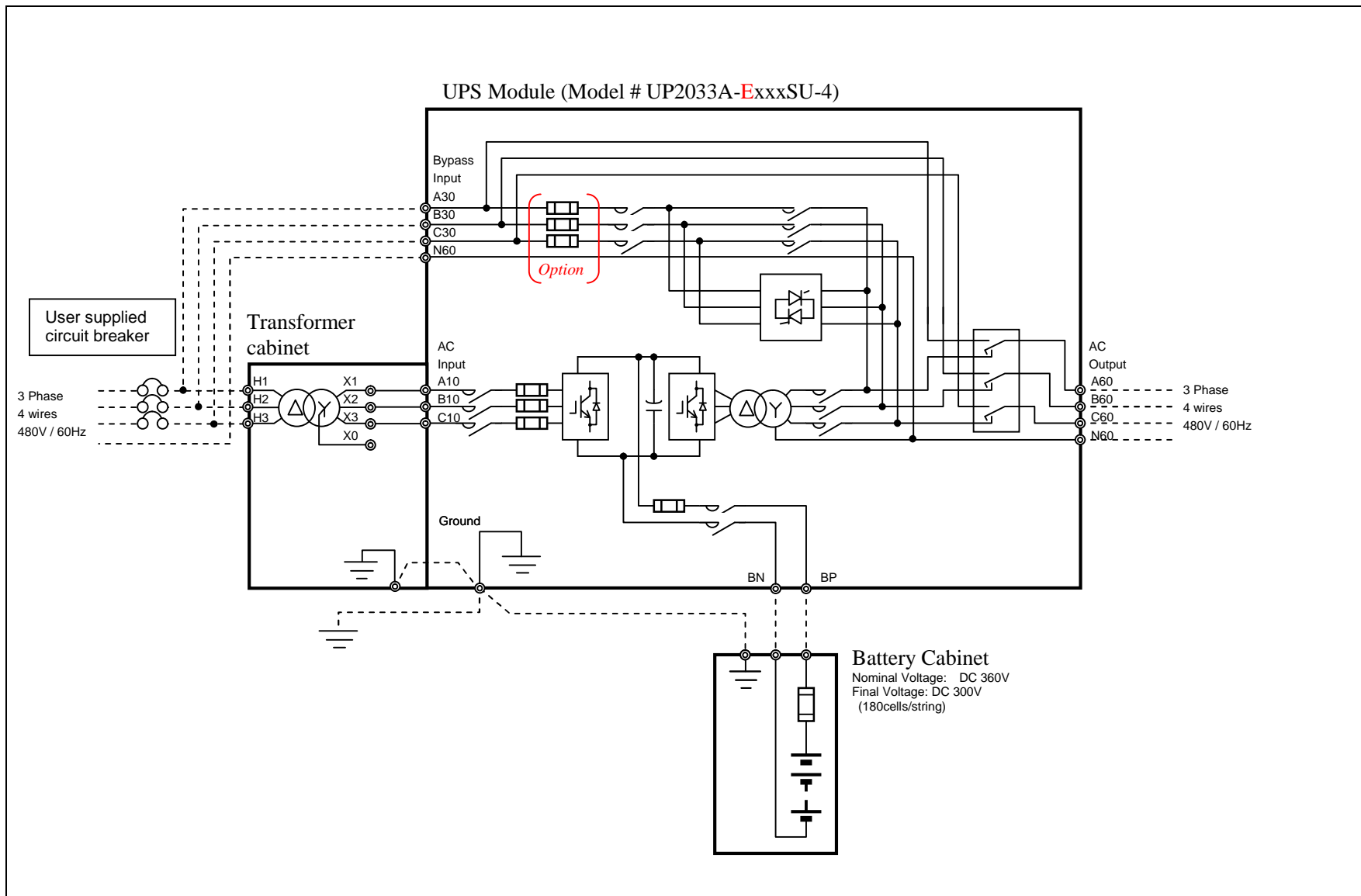

**FIGURE 3.3 h** Wiring configuration for 480V input / 480V output with transformer cabinet. (One sources feeding the UPS)

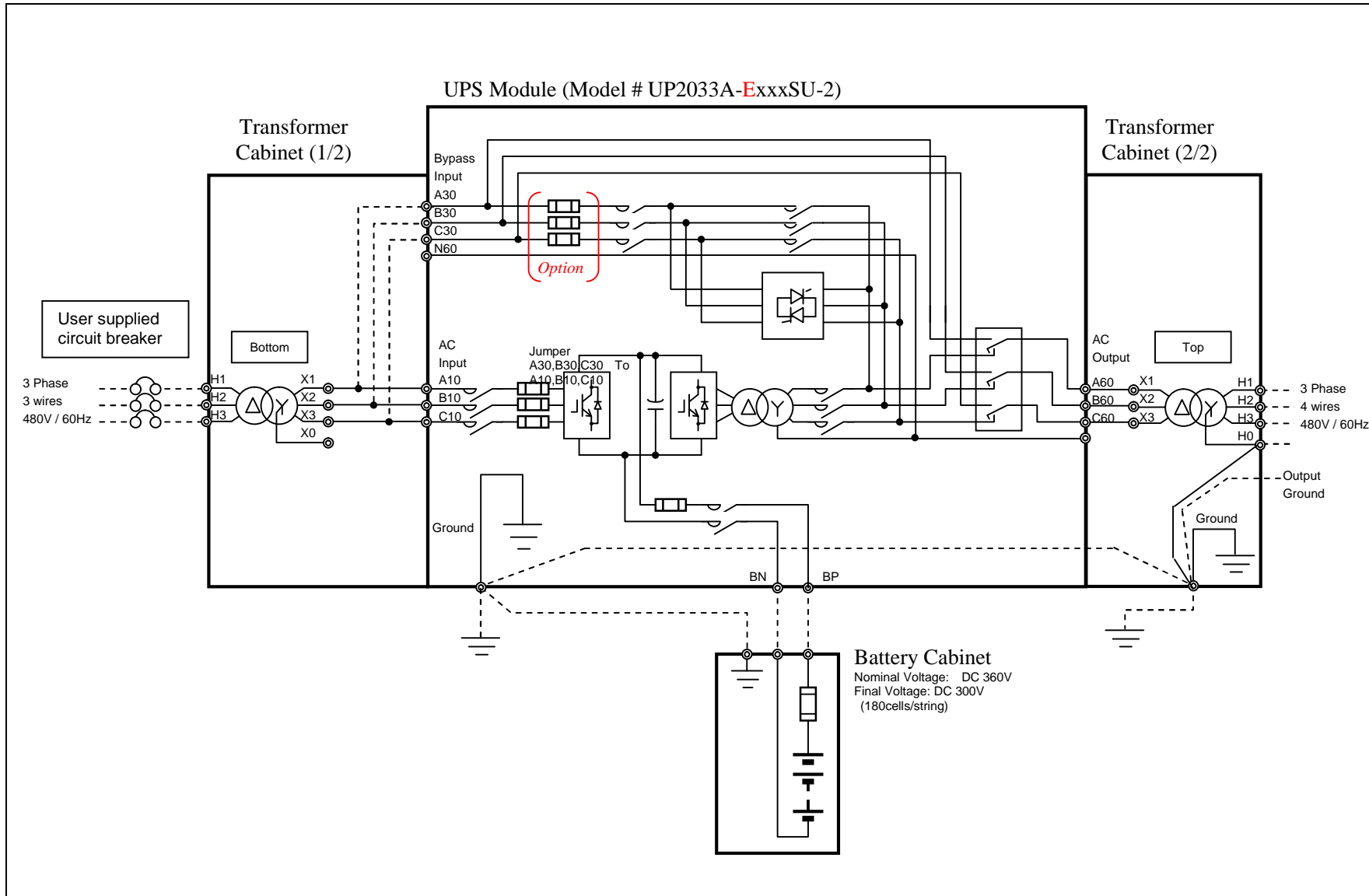
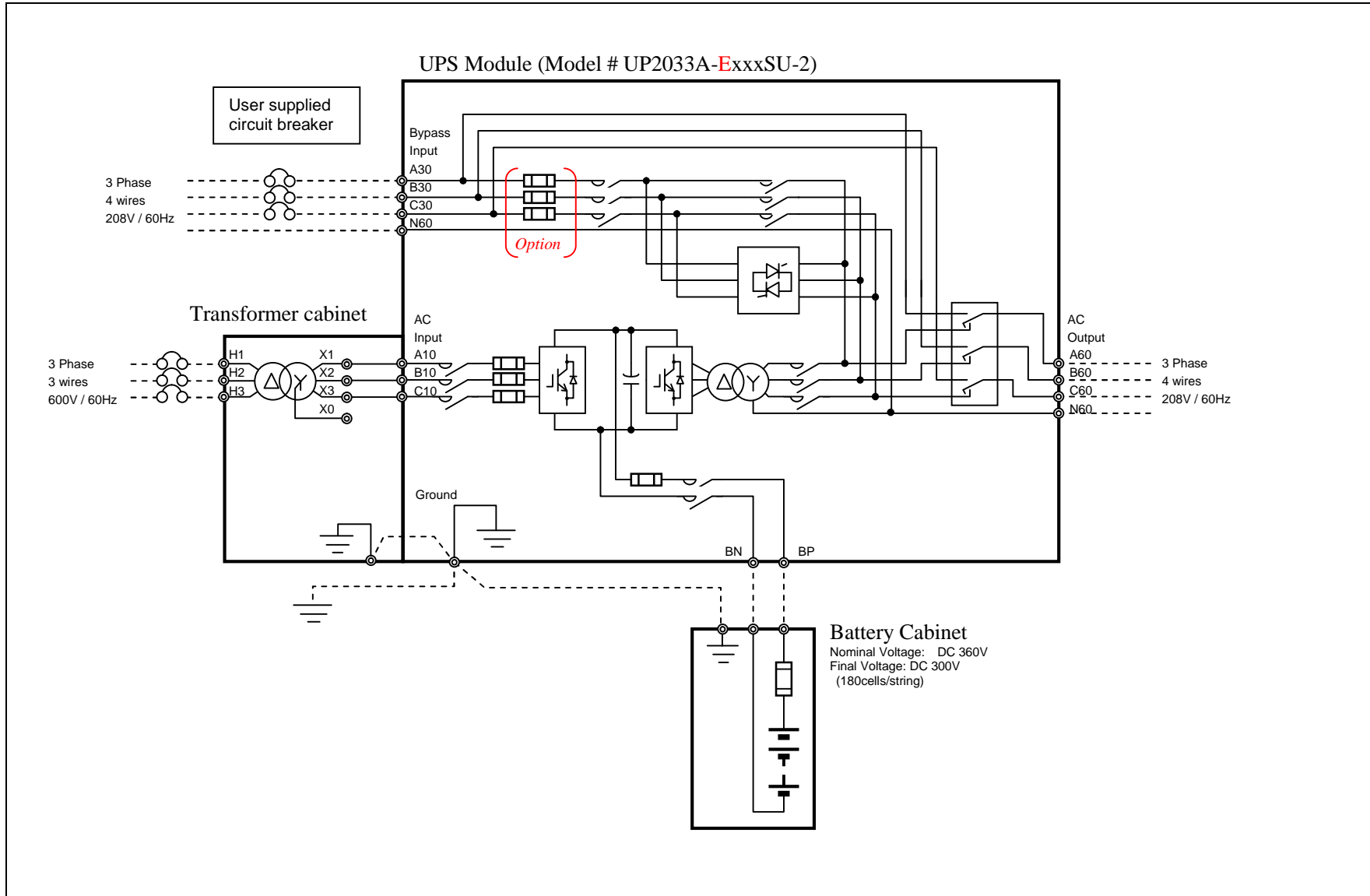



FIGURE 3.3 i Wiring configuration for 600V input / 208V output. (Two sources feeding the UPS)



**FIGURE 3.3 j** Wiring configuration for 600V input / 208V output. (One sources feeding the UPS)

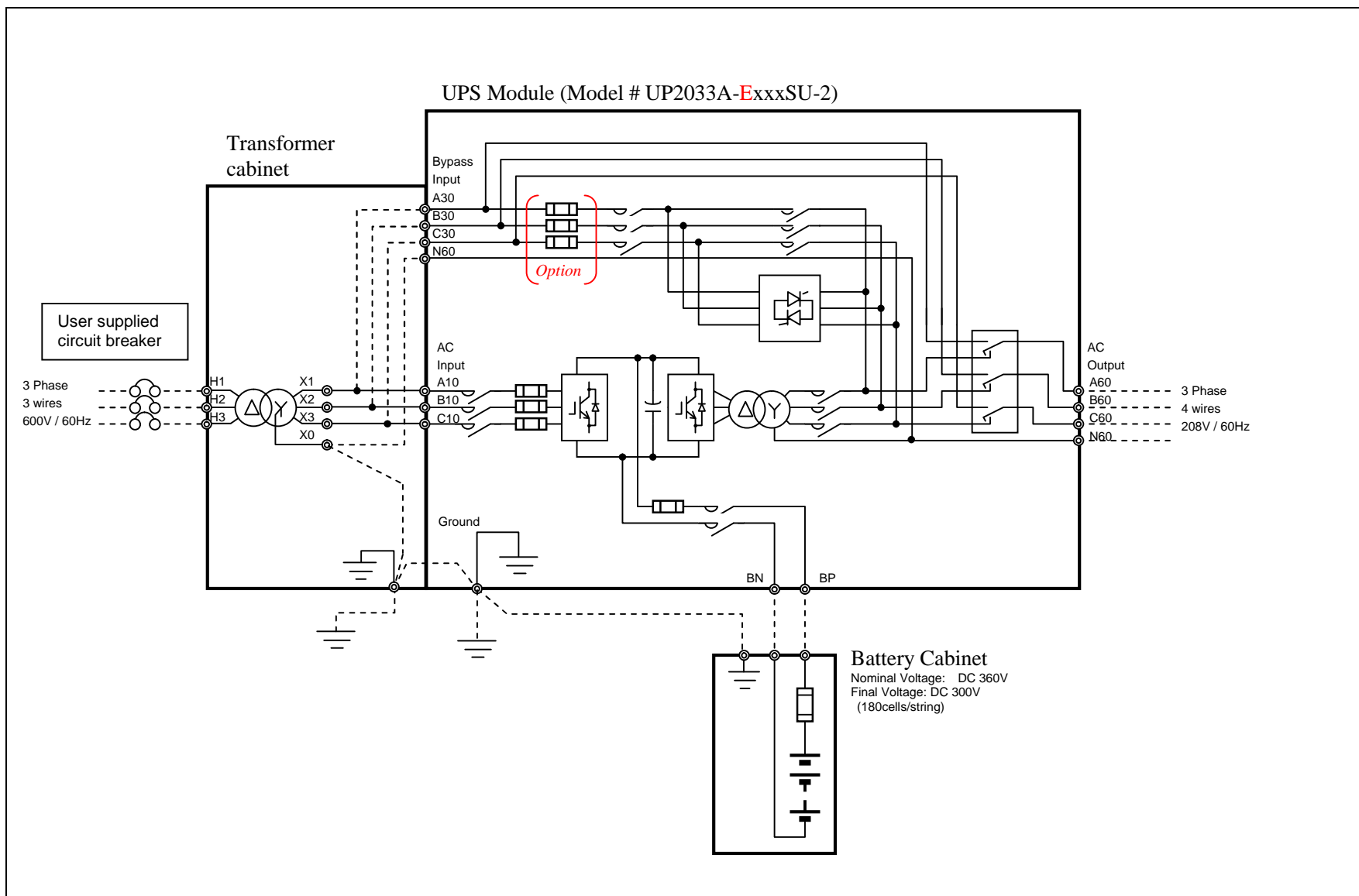



FIGURE 3.3 k Wiring configuration for 600V input / 600V output. (Two sources feeding the UPS)

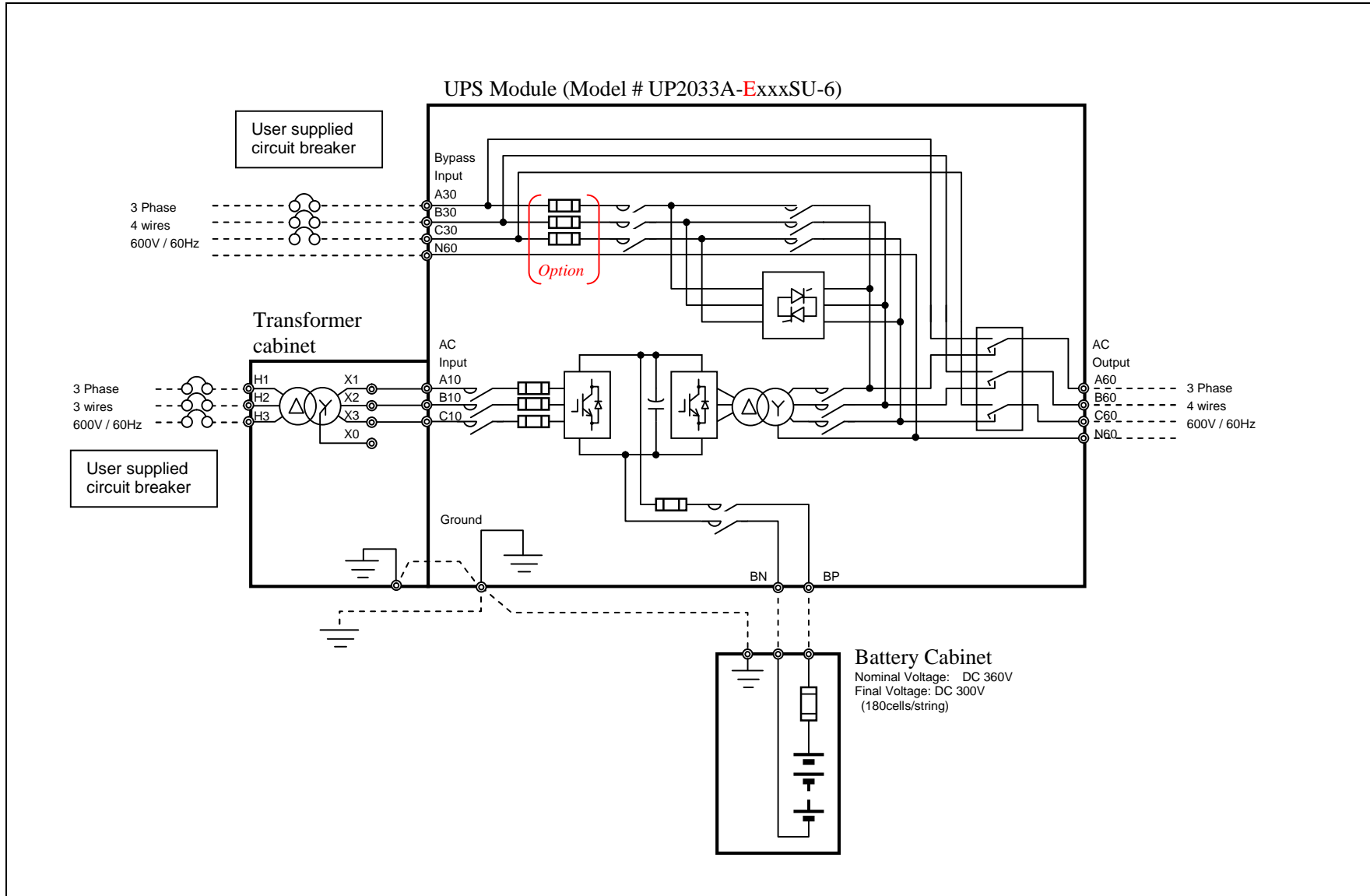
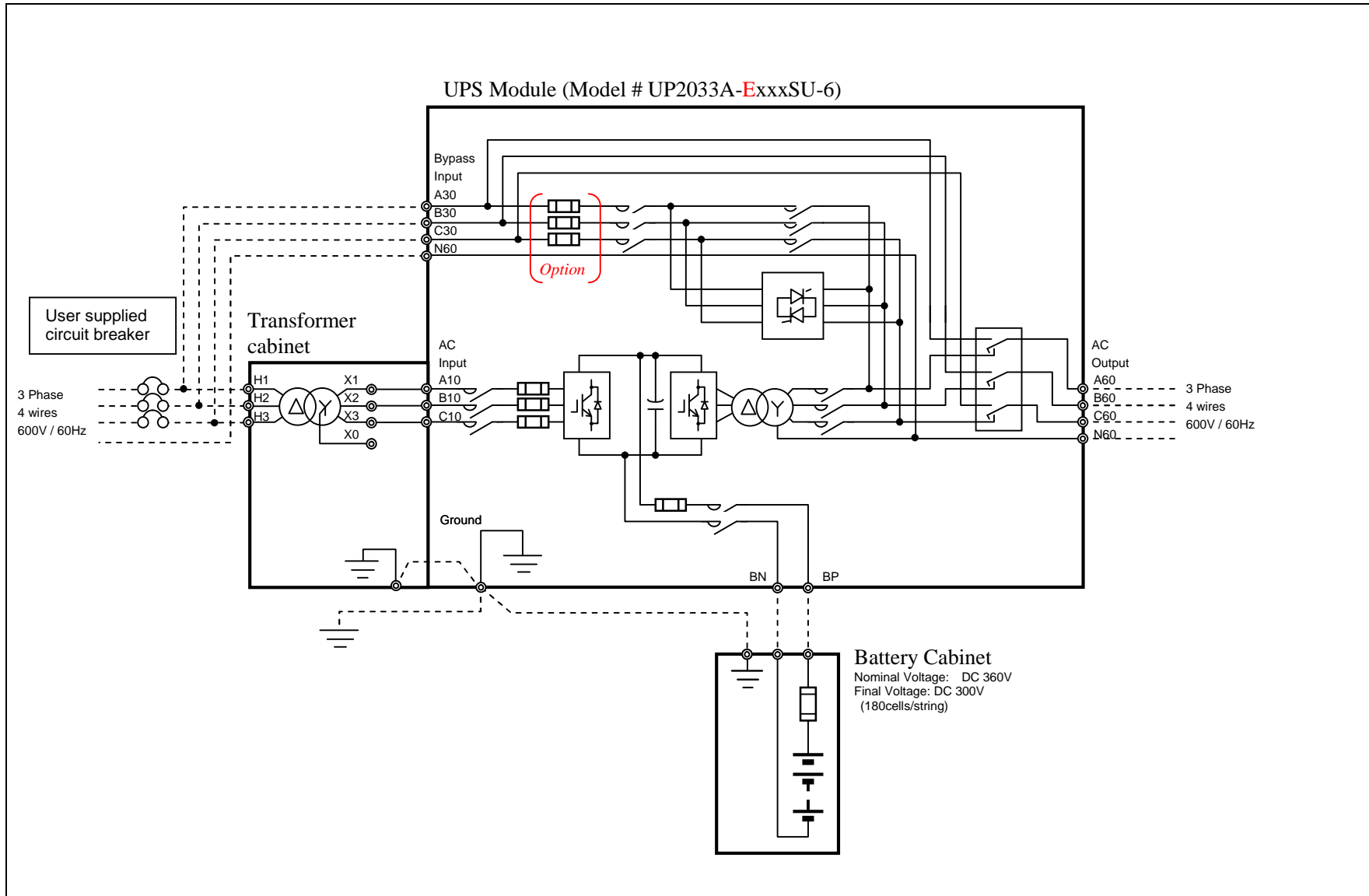
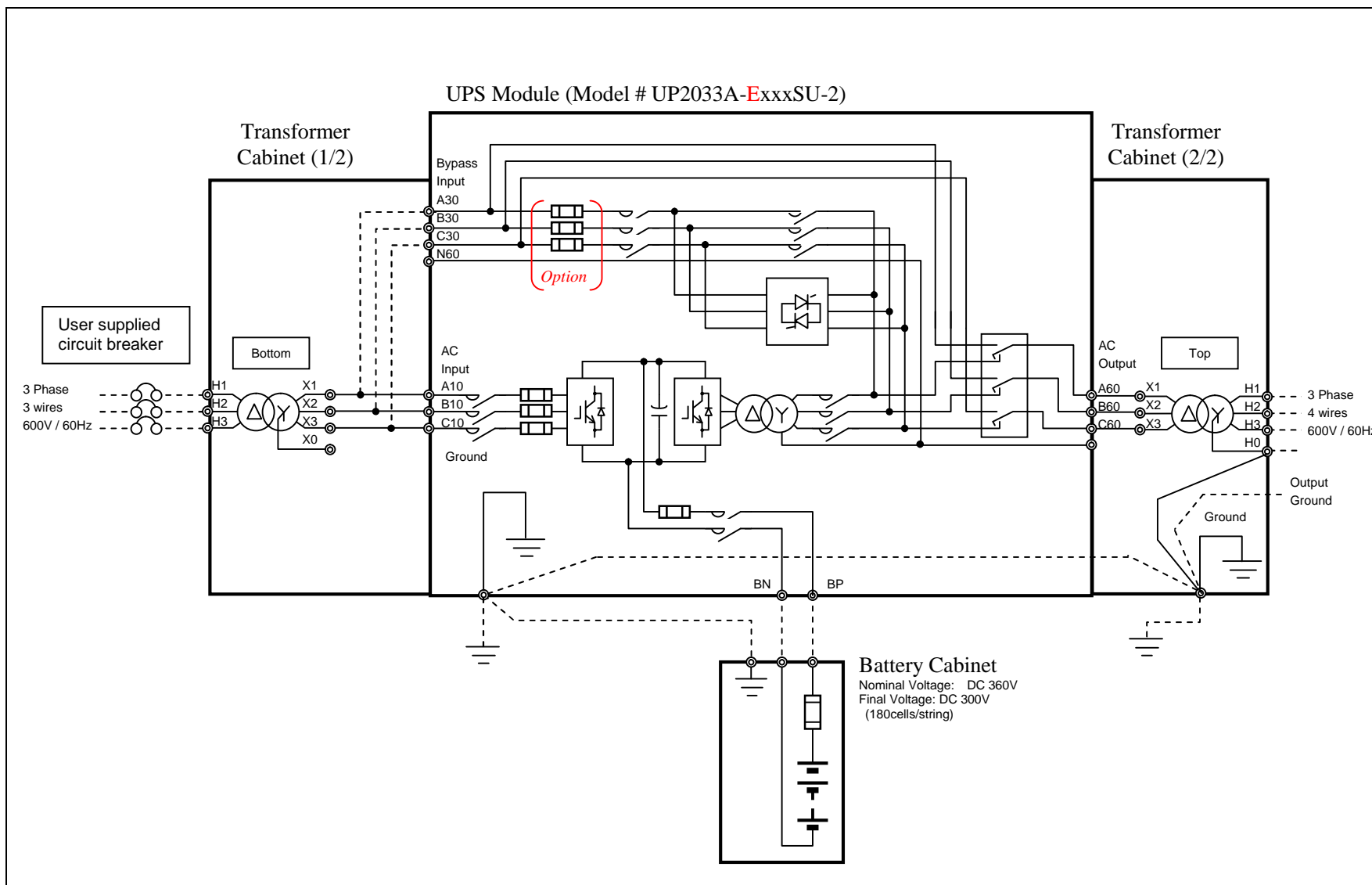



FIGURE 3.3 I Wiring configuration for 600V input / 600V output. (One sources feeding the UPS)



**FIGURE 3.3 m** Wiring configuration for 600V input / 600V output with transformer cabinet. (One sources feeding the UPS)



### 3.4 Operating Procedures

#### A) UPS Start-up Procedure

1. Verify that SW2 (contactor CB3 operator) is in the OFF position.
2. Close Control Circuit Breaker (CB101).
3. Verify that the External Bypass input Circuit Breaker(user supplied. Refer to warning 2) is closed. Place SW2 in the ON position.
4. Within about ten (10) seconds the AC Input Circuit Contactor (CB1), followed by the Battery Disconnect Circuit Contactor (CB2), will automatically close.
5. The audible annunciator will sound and the instruction "PRESS START / STOP KEY" will be displayed on the LCD panel. ( Figure 3.4)
6. Press the "Inverter Start" key in the START/STOP menu on the LCD panel. (Figure 3.5)

**FIGURE 3.4 START-UP MENU**

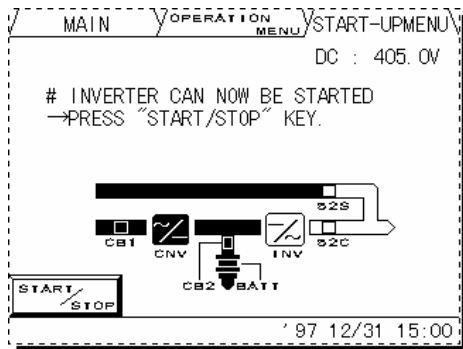

**FIGURE 3.5 INVERTER START/STOP**

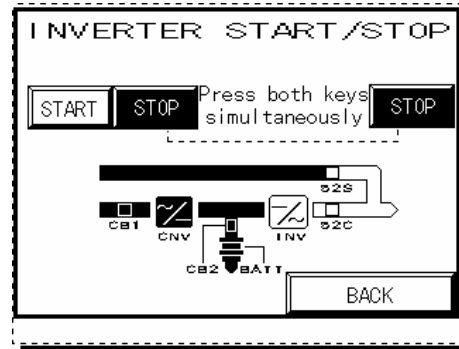

7. When the message "LOCAL" is displayed on the LCD panel, the inverter start operation can only be performed locally at the UPS front panel. When the message "REMOTE" is displayed on the LCD pane, the inverter start operation can be started by remote operation only. Lock-out of one inverter start mode is inherent and cannot be.
8. If a local inverter start operation is required (at the UPS), select "Local" in "Remote/Local" function via the Operation menu. Select "LOCAL" mode.
9. Within five (5) seconds, the Inverter will start-up and begin supplying power to the critical load.
10. If power is not supplied to the load, follow the instructions on the LCD panel.

#### B) UPS Shutdown Procedure

1. If a total UPS shutdown is required, verify that the critical load is OFF.

2. Select "STOP MENU" from the Operations menu.
3. Press the "INVERTER STOP" key in the START/STOP menu on the LCD panel. The UPS will transfer the load to the static bypass line.
4. When the "LOCAL" is displayed on the LCD panel, the operation can be performed at the UPS front panel. When the "REMOTE" is displayed on the LCD pane, the Inverter can be stopped by remote operation only. If the inverter stop operation is required locally (at the UPS), select to "LOCAL" from the "Remote/Local" selection in the Operations menu. Select "Local" mode.
5. Generally, the Inverter alone will be stopped and the Converter will remain energized to float-charge the batteries.

If stopping the converter is required, open control circuit breaker CB101. The battery disconnect contactor (CB2) and the converter input contactor (CB1) will both open automatically.



**WARNING** : *Verify the load is OFF if the next step is to be performed.*



**NOTE** : *Power to the critical load is supplied through the static bypass line. Power to the critical will be lost after execution of the next step. The load will drop.*

6. If turning off all power to critical load is desired, open the Bypass input Circuit Breaker(MCCB inside the user's cabinet) manually.
7. Contactor CB3 will open automatically.



**CAUTION** : *All UPS power terminals are still live. Lethal voltages present. De-energize all external sources of AC and DC voltages before handling UPS.*

### 3.5 Internal Maintenance bypass set-up procedure

#### A) Transfer of load from inverter to internal maintenance bypass

1. Stop the inverter by pressing the START/STOP key on the LCD's Main Menu. Simultaneously press the tow (2) STOP keys per the instructions. (Note : inverter STOP function inhibited if bypass and inverter are out of sync.)

2. Confirm via the flow diagram on the LCD that the load is fed from the UPS' static bypass line.
3. After confirming Step2, rotate cam switch from NORMAL (UPS) to BYPASS (maintenance bypass).
4. UPS can now be powered down per instructions on the LCD's OP. MENU.
5. Transfer is now complete. Load is fed from external source (Utility or generator).

**B) Transfer of load from internal maintenance bypass to inverter**

1. Confirm SW2 is closed and Static Bypass line is on and energized.
2. Close CB101.
3. Confirm via the flow diagram on the LCD that the UPS's output is fed from the static bypass line.
4. After confirming Step2, rotate cam switch from BYPASS (maintenance bypass) to NORMAL (UPS).
5. Press inverter START key on LCD to transfer load to inverter.
6. Transfer is now complete. Load is protected by UPS.

**3.6 Maintenance bypass set-up procedure for Input Trans/MBP Combination Cabinet****A) Transfer of load from inverter to external maintenance bypass**

1. On the UPS LCD, select "Operation Menu". Select "Stop Menu". Press "Start/Stop" key. Press both "Stop" keys simultaneously to turn inverter OFF.
2. Confirm with flow diagram on UPS LCD that the load is fed via UPS' static bypass line. DO NOT PROCEED IF LOAD IS NOT FED VIA STATIC BYPASS.
3. After confirming step 2 on MBP, press and hold pushbutton for SLU. While holding pushbutton rotate key in SLU counterclockwise and remove. Release pushbutton.
4. Insert key from SLU into Key Interlock for SW2. Rotate key clockwise to unlock SW2. Close SW2 on MBP.
5. On MBP, open SW3. Rotate key in key interlock on SW3 counterclockwise to lock SW3 open. Remove key. Load is now on utility or generator.
6. Insert key from SW3 into SLU and rotate clockwise.
7. On MBP, open SW1. Transfer is complete. The UPS is now isolated from the load. Power down UPS per instructions in "Stop Menu" referenced in step (1) above.

For full electrical isolation of dual input feeds to UPS open the External AC Input Circuit Breaker (user supplied) and Battery Disconnect, if applicable (external to UPS).

**B) Transfer of load from external maintenance bypass to inverter**

1. On MBP, close SW1. If UPS has dual feeds, Verify/Close External AC Input Circuit Breaker (user supplied) for UPS and Battery Disconnect if applicable.
2. On UPS LCD, select "Operation Menu". Select "Start Menu". Start UPS and Inverter per instructions.
3. On UPS LCD, select "Operation Menu". Select "Stop Menu". Stop Inverter per instructions.
4. Confirm with flow diagram on UPS LCD that load is fed via UPS' static bypass line. DO NOT PROCEED IF LOAD IS NOT FED VIA STATIC BYPASS.
5. Press SLU pushbutton and rotate key for SLU counterclockwise and remove.
6. On MBP, insert key from SLU into key interlock for SW3. Rotate key clockwise to unlock, close SW3.
7. On MBP, open SW2. Rotate key counterclockwise to lock SW2 in the open position. Remove the key from SW2 and insert into SLU and rotate clockwise.
8. On the UPS LCD, select "Start/Stop Menu". Select "Start Menu". Press "Start" key to turn inverter ON.
9. Confirm with the flow diagram on the LCD that load is fed via UPS' inverter.
10. Transfer is now complete. Load is protected by UPS.

#### 4.0 RESPONSE TO UPS FAILURE

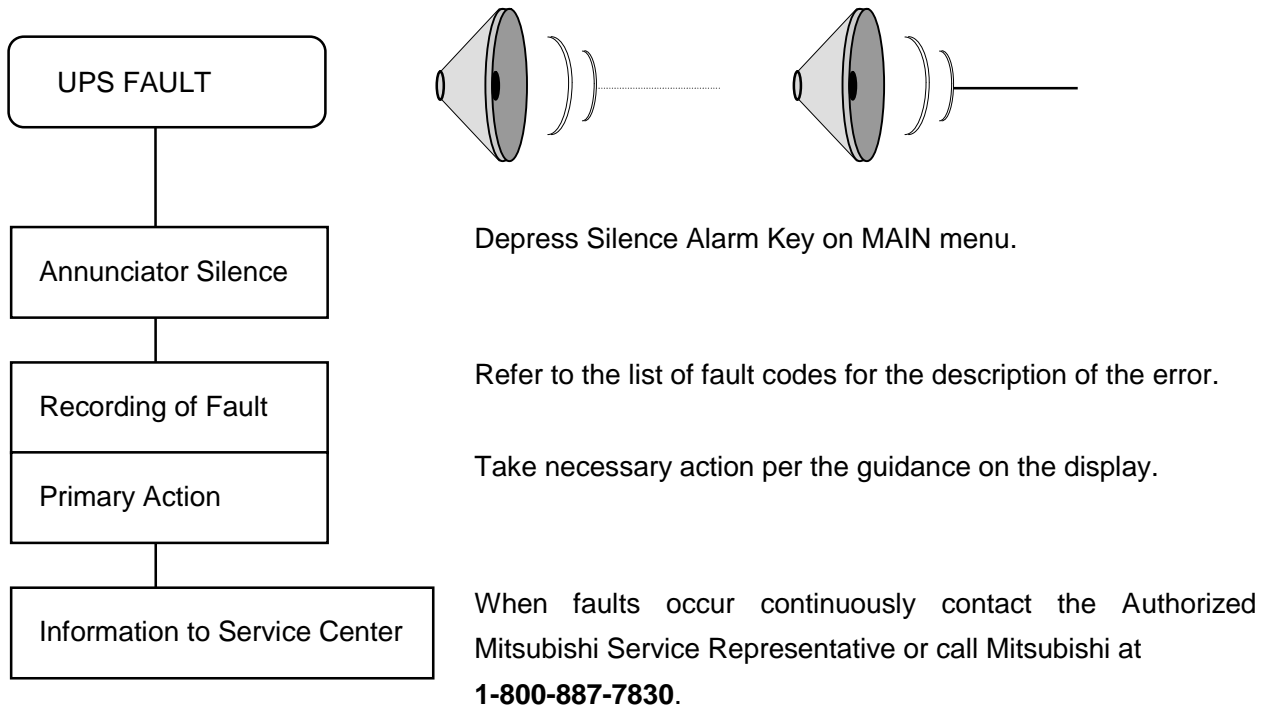

**Note**

The error code indicated on the LCD display panel at the time of UPS alarm condition is very important. In order to reduce repair time, please include this information, along with the operation status and load status, on all correspondence with Mitsubishi field service group.

## 5.0 PARTS REPLACEMENT

Contact Mitsubishi or its Authorized Service Center on all issues regarding the replacement of parts.

### A) **Battery**

Battery lifetime may vary according to the frequency of use and the average ambient operating temperature. Battery end of life is defined as the state of charge resulting in an ampere-hour capacity less than, or equal to, 80% of nominal capacity. Replace battery if capacity is within this percentage.

### B) **UPS Component Parts**

Contact Mitsubishi or its Authorized Service Center for a complete parts replacement schedule. Recommended replacement time interval varies with operating environment. Contact Mitsubishi or its Authorized Service Center for application specific recommendations.

## 6.0 FAULT CODES

This section covers the fault codes, their description and required action.

At time of error :

- A) Verify and record the occurrence of the alarm. Note details of alarm message on the LCD display panel.

***Contact Mitsubishi Electric Power Products, Inc. at 1-800-887-7830.***

- B) If a circuit breaker (MCCB) is in the trip state, depress the toggle to reset the breaker before closing it again.

### Fault Code List

Note 11. Code indication	Status message	Contents	Note 1 Guidance	Note 2 Buzzer	Note 3 External send-out contact	Note 4 Failure lamp
UF003	CONVERTER ABNORMAL	Preliminary charge impossible	1	[2]	Major	Lit up
UF052	CB1 TRIPPED	Input circuit breaker CB1 has tripped	1	[1]	Minor	Flicker
UF053	CB1 ABNORMAL	Input circuit breaker CB1 abnormal	1	[1]	Minor	Flicker
UF056	CONVERTER OVERLOAD	Converter input overcurrent	1	[1]	Minor	Flicker
UF059	CONVERTER ABNORMAL	Converter control circuit abnormality	1	[1]	Minor	Flicker
UF060	CONVERTER ABNORMAL	Converter IPM abnormal	1	[2]	Major	Lit up
UF102	DC OVERVOLTAGE	Overvoltage of DC voltage	1	[2]	Major	Lit up
UF103	DC UNDERVOLTAGE	Low voltage of DC voltage	1	[2]	Major	Lit up
UF105	SENSOR ABNORMAL	DC voltage sensor circuit abnormality	1	[2]	Major	Lit up
UF106	DC CAPACITANCE ABNORMAL	Electrolytic capacitor abnormality	1	[2]	Major	Lit up
UF107	CB2 ABNORMAL	Battery disconnect circuit breaker CB2 abnormal	1	[2]	Major	Lit up
UF151	DC VOLTAGE ABNORMAL	Does not return to float voltage after power supply is resumed (24 hours)	2	[1]	Minor	Flicker
UF152	DC VOLTAGE ABNORMAL	Does not return to equalizing voltage after power supply is resumed	2	[1]	Minor	Flicker
UF153	CB2 TRIPPED	Battery disconnect circuit breaker CB2 has tripped.	1	[1]	Minor	Flicker
UF154	CB2 ABNORMAL	CB2 turned OFF	1	[1]	Minor	Flicker
UF156	CB2 TRIPPED (BATTERY OVERTEMPERATURE)	Battery temperature abnormality (UF157) lasted a long time (Note 6)	1	[1]	Minor Note 5	Flicker
UF157	BATTERY OVERTEMPERATURE	Battery temperature abnormality	2	[1]	Minor Note 5	Flicker
UF158 (Note10)	BATTERY LIQUID LEVEL LOW	Battery solution level drop (Note 7)	2	[1]	Minor Note 5	Flicker
UF160	SENSOR ABNORMAL	Sensor abnormality of battery circuit	1	[1]	Minor	Flicker
UF161	CB2 TRIPPED (DC VOLTAGE ABNORMAL)	Does not return to float voltage after power supply is resumed (48 hours) (Note 6)	2	[1]	Minor	Flicker
UF162	BATTERY ABNORMAL	Battery abnormal detected by battery self test.				
UF201	INVERTER OVERVOLTAGE	Output overvoltage during inverter power supply (+ 15%)	1	[2]	Major	Lit up
UF202	INVERTER UNDERVOLTAGE	Output low voltage during inverter supply (- 15%)	1	[2]	Major	Lit up
UF203	INVERTER OVERCURRENT	Inverter output overcurrent	1	[2]	Major	Lit up
UF209	52C ABNORMAL	52C not turned ON	1	[2]	Major	Lit up
UF210	52C ABNORMAL	52C not turned OFF	1	[2]	Major	Lit up
UF212	FAN ABNORMAL	Fan power source abnormality during operation	1	[2]	Major	Lit up
UF213	INVERTER OR CONVERTER OVERTEMPERATURE	Overheating of main circuit parts	1	[2]	Major	Lit up
UF214	COOLING FAN ABNORMAL	Abnormality of cooling fan inside panel	1	[2]	Major	Lit up
UF216	INVERTER ABNORMAL	Inverter IPM abnormal	1	[2]	Major	Lit up
UF255	52C ABNORMAL	52C turned OFF during inverter power supply	1	[1]	Minor	Flicker

Note 11. Code indication	Status message	Contents	Note 1 Guidance	Note 2 Buzzer	Note 3 External send-out contact	Note 4 Failure lamp
UF256	OUTPUT VOLTAGE ABNORMAL	Inverter output voltage fell out of +/- 5%	1	[1]	Minor	Flicker
UF257	52C ABNORMAL	52C not turned OFF when manual transfer	1	[1]	Minor	Flicker
UF258	OVERLOAD	Frequent overload	4	[1]	Minor	Flicker
UF301	UPS CONTROL CIRCUIT ERROR	Control microcomputer abnormality	1	[2]	Major	Lit up
UF302	UPS CONTROL CIRCUIT ERROR	Control microcomputer abnormality	1	[2]	Major	Lit up
UF303	UPS CONTROL CIRCUIT ERROR	Control microcomputer abnormality	1	[2]	Major	Lit up
UF304	UPS CONTROL CIRCUIT ERROR	Control microcomputer abnormality	1	[2]	Major	Lit up
UF305	UPS CONTROL CIRCUIT ERROR	Control circuit abnormality	1	[2]	Major	Lit up
UF306	UPS CONTROL CIRCUIT ERROR	Control power source circuit abnormality	1	[2]	Major	Lit up
UF309	INVERTER VOLTAGE ABNORMAL	Inverter output voltage abnormality before inverter power supply	1	[2]	Major	Lit up
UF351	CONTROL FUSE BLOWN	Battery circuit's fuse burnt	1	[1]	Minor	Flicker
UF352	SUPPLY OF CONTROL CIRCUIT ABNORMAL	Control circuit abnormality	1	[1]	Minor	Flicker
UF355 (Note10)	UPS CONTROL CIRCUIT ERROR	Control circuit abnormality	1	[1]	Minor	Flicker
UF356	UPS CONTROL CIRCUIT ERROR	Control circuit abnormality	1	[1]	Minor	Flicker
UF357	"INVERTER START " BUTTON ABNORMAL	"INVERTER START" button is abnormal (Local)	1	[1]	Minor	Flicker
UF358	"INVERTER STOP " BUTTON ABNORMAL	"INVERTER STOP" button is abnormal (Local)	1	[1]	Minor	Flicker
UF359	"INVERTER SUPPLY" BUTTON ABNORMAL	"INVERTER SUPPLY" button is abnormal	1	[1]	Minor	Flicker
UF360	"BYPASS SUPPLY" BUTTON ABNORMAL	"BYPASS SUPPLY" button is abnormal	1	[1]	Minor	Flicker
UF362	UPS CONTROL CIRCUIT ERROR	52S control circuit abnormality (Note 8)	1	[1]	Minor	Flicker
UF401	52S ABNORMAL	52S not turned ON, or 52S turned ON without any command	1	[2]	Major	Lit up
UF402	52S ABNORMAL	52S not turned OFF, or 52S turned OFF without any command	1	[2]	Major	Lit up
UF451	52S ABNORMAL	52S not turned ON, or 52S turned ON without any command when manual transfer	1	[1]	Minor	Flicker
UA801	AC INPUT VOLTAGE OUT OF RANGE	AC input voltage fell out of +/- 18% range	3	[1]	Note 5	Flicker
UA802	AC INPUT FREQUENCY OUT OF RANGE	Ac input frequency fell out of converter synchronization follow-up range	3	[1]	Note 5	Flicker
UA803	AC INPUT PHASE ROTATION ERROR	Phase rotation is inverted when input voltage is normal	3	[1]	Note 5	Flicker
UA804	CONVERTER ABNORMAL	CONV switch was turned off.	1	[1]	Note 5	Flicker
UA805 (Note10)	AMBIENT TEMPERATURE ABNORMAL	Temp. abnormality in room where installed	11	[1]		Flicker
UA806	INVERTER OVERLOAD > 100%	Overload exceeded 105% (Note 9)	4	[1]	Over	Flicker
UA808	INVERTER OVERLOAD > 125%	Overload exceeded 125% (Note 9)	4	[1]	Over	Flicker
UA809	INVERTER OVERLOAD > 150%	Overload exceeded 150% (Note 9)	4	[1]	Over	Flicker
UA810	OVERLOAD	Momentary over-current during Inverter power.	4	[1]	Over	Flicker

Note 11. Code indication	Status message	Contents	Note 1 Guidance	Note 2 Buzzer	Note 3 External send-out contact	Note 4 Failure lamp
UA811	BYPASS VOLTAGE OUT OF RANGE	Bypass voltage fell out of +/- 10% range at manual transfer	5	[1]	Note 5	Flicker
UA812	BYPASS VOLTAGE OUT OF RANGE	Bypass voltage fell out of +/- 20% range	5	[1]	Note 5	Flicker
UA813	BYPASS PHASE ROTATION ERROR	Phase rotation is inverted when bypass voltage is normal	5	[1]		Flicker
UA814	BYPASS FREQUENCY OUT OF RANGE	Bypass frequency fell out of inverter synchronization follow-up range	5	[1]	Minor Note 5	Flicker
UA816	EXTENDED BYPASS OPERATION	Bypass power supply continued for many hours		[1]		Flicker
UA817	EMERGENCY STOP ACTIVATED	Emergency stop applied	13	[2]	Minor	Flicker
UA818	TRANSFER ABNORMAL	Transfer cannot be permitted because Bypass voltage abnormal	5	[1]		Flicker
UA819	REMOTE SWITCH ON(START)	There is an error with the remote start switch.	12	[1]		Flicker
UA820	REMOTE SWITCH ON(STOP)	There is an error with the remote stop switch.	12	[1]		Flicker
UA821	UPS STOPPED (TRANSFER INHIBITED - INVERTER AND BYPASS ASYNCHRONOUS)	Transfer cannot be permitted because Bypass voltage abnormal	5	[1]		Flicker
UA822	GENERATOR OPERATION , INHIBITED BYPASS OPERATION	Transfer cannot be permitted because Generator operation contact is ON		[1]		Flicker
UA824	CB2 OFF	Battery disconnect circuit breaker CB2 turned OFF	7	[1]		Flicker
UA826	CB101 OFF	Control power source breaker CB101 turned OFF during inverter operation	8	[1]		Flicker
UA830	AC INPUT UNDERVOLTAGE	AC input voltage fell out of - 10% range	3	[1]		Flicker
UA831	EMERGENCY BYPASS SWITCH ON	Emergency bypass switch turned to <Emergency>	10	[1]		Flicker
UA832	INTERRUPTED TRANSFER OCCURRED WHEN TRANSFERRING TO BYPASS SOURCE	When transfer to the bypass supply, occurs interrupted transfer.	5	[1]		Flicker
UA834	BATTERY DEPLETED	DC voltage dropped below discharge end during inverter operation	10	[2]	Note 5	
UA835	UPS STOPPED (TRANSFER INHIBITED - BYPASS INPUT ABNORMAL)	Transfer cannot be permitted because Bypass voltage is abnormal		[1]		Flicker
UA836	OVERLOAD	Converter overload	5	[1]		Flicker

(Note 1) Numbered guidance:

- 1: Contact Mitsubishi.
- 2: Verify battery is operating within recommended voltage and temperature ranges.
- 3: Verify input power source is properly connected.
- 4: Reduce load.
- 5: Verify bypass power source is within amplitude and frequency.
- 6: Close CB1.
- 7: Close CB2.
- 8: Close CB101.
- 9: Reduce load and restart.
- 10: Press the reset button.
- 11: Reduce room temperature to within specified UPS operating limits
- 12: Verify remote switch is properly connected and/or functional.
- 13: Place switch in OFF position.

(Note 2)

Audible annunciator: [1] intermittent sound, [2] continuous sound.

(Note 3)

- "Major" is defined as major failure. Inverter transferred to the static bypass line;
- "Minor" is defined as a minor failure. UPS continues to operate normally, but cause of alarm must be identified;
- "Over" is defined as an overload condition. UPS will transfer to the static bypass line and may or may not return to the inverter. Return to inverter will occur only if overload corrects itself and output load is within rating of UPS.

(Note 4)

Indicates one of two possible LED illumination patterns - continuously on (lit) or intermittent (flicker).

(Note 5)

External send-out possible by option setting.

(Note 6)

Trips the battery breaker CB2.

(Note 7)

For other than sealed-type battery.

(Note 8)

Place UPS Emergency Bypass switch in the BYPASS position. Contact Mitsubishi.

(Note 9)

If the specified time passes, will transfer to the bypass power supply.

(Note 10)

Shows only when corresponding option settings are made.

(Note 11)

Code indication means:

UA□□□-----	Alarm
UF□□□-----	Failure
U□0□□-----	Converter circuit failure
U□1□□-----	DC circuit failure
U□2□□-----	Inverter circuit failure
U□3□□-----	Control circuit failure
U□4□□-----	Bypass system failure
U□8□□-----	Alarm
U□□00 - U□□49 -----	Major failure
U□□50 - U□□99 -----	Minor failure

## 7.0 WARRANTY & OUT OF WARRANTY SERVICE

The Mitsubishi Electric UPS Division Service Department has many Authorized Service Centers place strategically throughout the US, Canada and Latin America. For both in warranty and out of warranty service, please contact Mitsubishi Electric Power Products, Inc. at (847) 478-2100. To register your UPS for warranty purposes, please complete the warranty registration form and fax it to the Mitsubishi Electric UPS Division Service Department fax line shown on the registration form. (Next page)

For warranty purposes, it is essential that any and all service work that may be required on your Mitsubishi brand UPS equipment is performed by a Mitsubishi Electric Authorized Service Center. The use of non-authorized service providers may void your warranty.

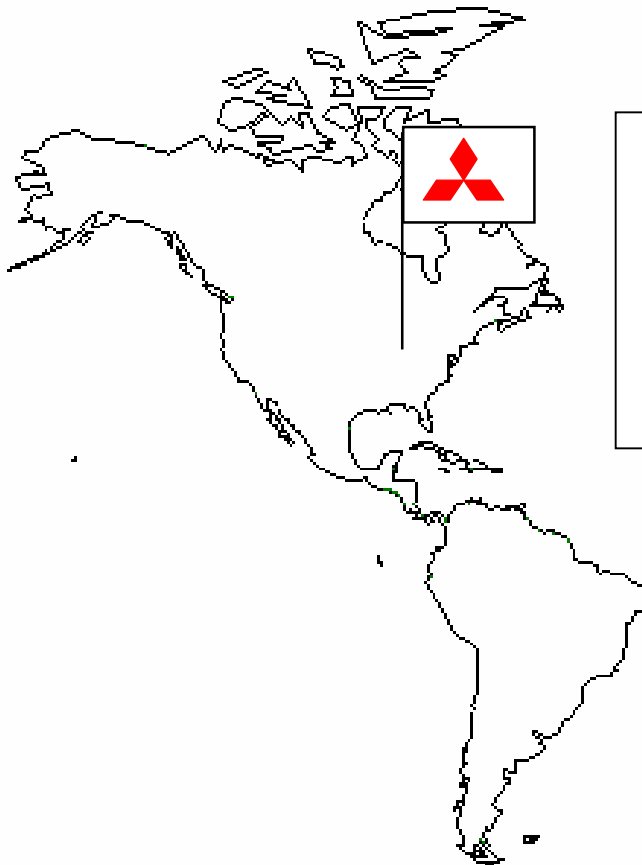
**Mitsubishi Electric Power Products, Inc**

UPS Division Service Department

500 Corporate Woods Parkway,

Vernon Hills, Illinois 60061, USA

Phone: (847) 478-2100

Fax: (847) 478-2290

**NOTE: PLEASE READ THE TERMS OF THIS LIMITED WARRANTY CAREFULLY PRIOR TO INSTALLATION AND START-UP OF YOUR NEW MITSUBISHI UNINTERRUPTIBLE POWER SUPPLY SYSTEM. FAILURE TO FOLLOW THESE PROCEDURES MAY VOID YOUR LIMITED WARRANTY!**

**MITSUBISHI ELECTRIC POWER PRODUCTS, INC.  
UNINTERRUPTIBLE POWER SUPPLY SYSTEM  
(2033A/2033C/2033D/9700/9800A SERIES)  
LIMITED WARRANTY POLICY AND PROCEDURES**

**1. LIMITED WARRANTY:** MITSUBISHI ELECTRIC POWER PRODUCTS, INC. ("MEPPI") warrants to the original end user that the 2033A/2033C/2033D/9700/9800A series Uninterruptible Power Supply Unit sold by MEPPI (the "Product") shall be free from defects in material and workmanship under normal use and service for a period of twenty four(24) months from the date of installation or thirty (30) months from the date of shipment of the Product, whichever comes first, the original end user (the "Warranty Period"). If MEPPI receives notice of any defects during the Warranty Period, MEPPI shall, at its option, repair or replace any defective parts, subject to the limitations and procedures described below.

**A. LIMITATIONS.** This Limited Warranty shall cover the Product only if all of the following conditions have been met:

- (1) If temporary on-site storage of the Product was required before installation, all prescribed storage requirements as set forth in MEPPI's published storage guidelines shall have been strictly followed.
- (2) MEPPI's UPS Divisions Service Department or a MEPPI Authorized Service Organization shall have inspected the installation site to determine correct application conditions and to perform any required inspections, calibrations and startup of the Product. Contact MEPPI at the number listed below to schedule startup of the Product.
- (3) This limited warranty does not include travel and related costs for Products installed outside the United States. Consult your local MEPPI representative for terms and conditions.

**B. EXCLUSIONS.** This Limited Warranty does not cover:

- (1) System batteries/battery plant and all other peripheral products and accessories not manufactured by MEPPI (including components or software) or the installation, operation, maintenance or service of such accessories. These items may be separately warranted by the manufacturer of the item in question.
- (2) Any Product whose serial number has been altered defaced or removed.
- (3) Any Product which has been damaged during shipment.
- (4) Product defects caused by installation, start-up, wiring, modification, alteration, repair, service or parts replacement except by MEPPI or an authorized MEPPI service representative. Contact MEPPI at the number below for a list of authorized service providers in your area.
- (5) Product defects caused by inadequate maintenance, misuse, physical abuse of the Product, accident, excessive stress or operation of the Product under abnormal environmental conditions or contrary to the Product's operating instructions.
- (6) Product defects caused by failure to follow the operational specifications or the handling and operational procedures prescribed in the Product Owner's Manual.
- (7) Service, repair or replacement of parts made necessary by any cause beyond MEPPI's control, including, but not limited to, fire, theft, lightning, acts of God, negligence, accident, excessive physical or electrical stress or operation under abnormal environmental conditions.
- (8) Products which have been decommissioned and/or relocated from the original installation site.

## C. ADDITIONAL LIMITATIONS

- (1) Parts used for replacements are warranted for the longer of 90 days or the remainder of the original Warranty Period. All defective Product parts shall be the property of MEPPI upon replacement. MEPPI reserves the right to make any or all changes to the Products that it may deem necessary without prior notice to customer. Replacement parts may be new or reconditioned or refurbished.
- (2) THIS LIMITED WARRANTY IS EXCLUSIVE, AND NO OTHER WARRANTY WHETHER WRITTEN OR ORAL, IS EXPRESSED OR IMPLIED. MEPPI SPECIFICALLY DISCLAIMS ANY IMPLIED WARRANTY OF MERCHANTABILITY AND FITNESS FOR ANY PARTICULAR PURPOSE, WHICH SHALL NOT BE APPLICABLE UNDER ANY CIRCUMSTANCES WHATSOEVER.
- (3) THIS LIMITED WARRANTY SHALL CONSTITUTE THE SOLE AND EXCLUSIVE REMEDY OF ALL PURCHASERS AND USERS OF THE PRODUCT. UNDER NO CIRCUMSTANCES SHALL MEPPI BE LIABLE FOR DAMAGES, WHETHER DIRECT, INDIRECT, SPECIAL, INCIDENTAL OR CONSEQUENTIAL BY REASON OF ANY DEFECTIVE PRODUCTS, BREACH OF THIS LIMITED WARRANTY, BREACH OF CONTRACT, TORT (INCLUDING NEGLIGENCE OR STRICT LIABILITY) OR OTHERWISE. IN NO EVENT SHALL MEPPI BE LIABLE FOR ANY AMOUNT IN EXCESS OF THE PURCHASE PRICE PAID FOR ANY PRODUCT FOUND TO BE DEFECTIVE.

## 2. PROCEDURES

### A. Direct all inquiries to:

MITSUBISHI ELECTRIC POWER PRODUCTS, INC.

Attention: UPS Division Service Department

500 Corporate Woods Parkway

Vernon Hills, Illinois 60061

Phone: (847) 478-2100

Fax: (847) 478-2290

B. All claims for warranty service shall be submitted to MEPPI at the address listed in 2A above. Claims shall be made in writing or by telephone or fax subsequently confirmed in writing and will be considered received on the day notice is actually received by MEPPI.

C. If MEPPI determines that the repair is covered under this Limited Warranty, MEPPI shall repair or replace the defective part at no charge to the customer. MEPPI shall advise the customer if it determines that the requested repair is not covered under this Limited Warranty. Upon customer's request, MEPPI shall perform the repair at the customer's cost and expense. Repair charges shall be based on service parts price and the prevailing field service-call charges in effect at the time of repair. All repair invoices shall be paid within 30 days of invoice date. Past due invoices shall bear interest at the rate of 1.5% per month, but not in excess of the maximum lawful rate, until paid in full. Customers are responsible for all costs and expenses, including attorneys' fees, incurred by MEPPI in collecting any past due invoices.

**3. EXTENDED WARRANTY:** The original end user may purchase an extension of this limited warranty for up to 36 months after the expiration of the original limited warranty. Extensions are available on new Product only (not previously placed in service) located at the site of the original end user; provided the Product has been continuously covered either by the original warranty or an extended warranty. Contact MEPPI for details prior to the expiration of your initial or extended limited warranty.

**4. MODIFICATIONS:** MEPPI may modify the procedures and charges described in this Limited Warranty at any time without prior notice to customer. No modification, waiver or alteration of any of the provisions of this Limited Warranty by customer shall be binding upon MEPPI, unless made in writing and signed by a duly authorized officer of MEPPI.

**5. GOVERNING LAW:** This Limited Warranty shall be subject to and construed solely in accordance with the laws of the United States of American and the State of Illinois, without regard to its principles of conflicts of law. The parties specifically disclaim the applicability of the United Nations Convention on the International Sale of Goods, as amended, and the United Nations Convention on the Limitation Period in the International Sale of Goods, as amended, to this Limited Warranty or any transaction or dispute arising hereunder.



**Mitsubishi Electric Power Products, Inc.**  
UNINTERRUPTIBLE POWER SUPPLIES  
500 Corporate Woods Parkway, Vernon Hills, IL 60061 Phone: (847) 478-2100, Fax: (847) 478-2290

## UPS Warranty Registration

 Register UPS for Warranty

 Address Change

**To validate the Warranty on your UPS this form must be filled out completely by Customer and returned.**

CUSTOMER INFORMATION		
Your Name:	Job Title:	
Company Name:		
Division / Department:		
Address:		
City:	State:	Zip Code:
Country:	Province:	
Business Phone:	Ext:	Fax:
E-Mail: _____ @ _____		Internet Address:
UPS Model #:	Capacity (kVA):	UPS Serial #:
Start-Up Date:     /     /	Authorized Mitsubishi Service Company (if known):	
Signature: _____		Date:     /     /

**Which ONE of These Best Describes Your Organization's Primary Business Classification?**

**Number of Employees at This Location is:**

- |  |   |  |           |              |                 |            |              |  |            |              |  |
|--|---|--|-----------|--------------|-----------------|------------|--------------|--|------------|--------------|--|
| <input type="checkbox"/> <b>{Energy Producer}</b><br><input type="checkbox"/> Utility<br><input type="checkbox"/> Alternate Energy<br><input type="checkbox"/> <b>{Manufacturing Co.}</b><br><input type="checkbox"/> OEM<br><input type="checkbox"/> Process<br><input type="checkbox"/> Consumer Goods<br><input type="checkbox"/> Electronics<br><input type="checkbox"/> Power Quality Equipment<br><input type="checkbox"/> <b>Commercial Business</b><br><input type="checkbox"/> <b>Electrical Contractor</b><br><input type="checkbox"/> <b>Healthcare</b><br><input type="checkbox"/> <b>Internet</b> | <input type="checkbox"/> <b>Education/Univ. Service</b><br><b>{Service}</b><br><input type="checkbox"/> Consulting<br><input type="checkbox"/> Engineering<br><input type="checkbox"/> Outsourcing<br><input type="checkbox"/> Financial/Legal/Insurance<br>{Expectations}<br><b>{Government}</b><br><input type="checkbox"/> Military<br><input type="checkbox"/> Municipals<br><input type="checkbox"/> Federal/State/Local<br><input type="checkbox"/> <b>Communications</b><br><input type="checkbox"/> <b>Distributors/Reps</b><br><input type="checkbox"/> <b>Other</b> _____ | <table style="width: 100%; border: none;"> <tr> <td style="width: 33%;">__ 1 – 19</td> <td style="width: 33%;">__ 100 - 249</td> <td style="width: 33%;">__ 1000 or more</td> </tr> <tr> <td>__ 20 – 49</td> <td>__ 250 - 499</td> <td></td> </tr> <tr> <td>__ 50 – 99</td> <td>__ 500 - 999</td> <td></td> </tr> </table> <p><b>Overall how was Start-Up performed:</b></p> <p>__ Unsatisfactory    __ Satisfactory    __ Exceeded</p> <p><b>Would you like to receive future product updates and news?</b></p> <p style="text-align: right;">__ Yes    __ No</p> | __ 1 – 19 | __ 100 - 249 | __ 1000 or more | __ 20 – 49 | __ 250 - 499 |  | __ 50 – 99 | __ 500 - 999 |  |
| __ 1 – 19  | __ 100 - 249  | __ 1000 or more  |           |              |                 |            |              |  |            |              |  |
| __ 20 – 49   | __ 250 - 499  |  |           |              |                 |            |              |  |            |              |  |
| __ 50 – 99   | __ 500 - 999  |  |           |              |                 |            |              |  |            |              |  |

**After Start-Up has been done Fax completed Form to:  
(847) 478-2290**